



DATA SHEET

SMD Round Spacer Support M1,2

Serie: N45013

**SMD Round Spacer
Support M1,2**

Serie No.: **N45013**

Customer:

DRW:	Jason	CHKD	Wilson	MATL:	Wilson	TOLERANCE	Mason	DATE	26.10.2018
APPD:	Schumi			FINISH	Jamy		Sheet No.		1 from 13



Technical Informations

Thread Size	M1,2
Body Material	11SMnPb30
Surface:	Tin Plated
Torque:	0,12Nm
Solder Paste Thickness	150µm
Pic and Place Pad Mat.	KAPTON

Technical Dimensions (mm)

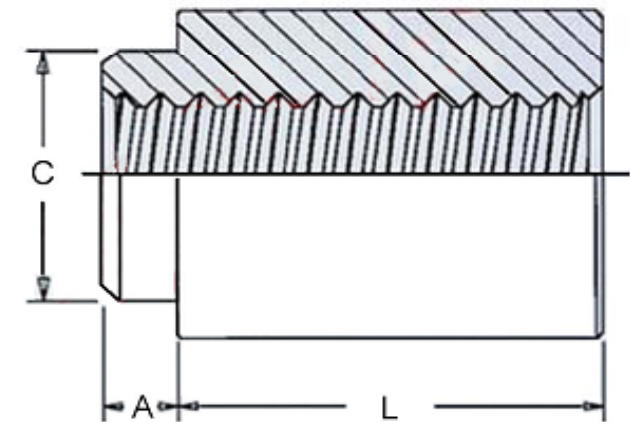
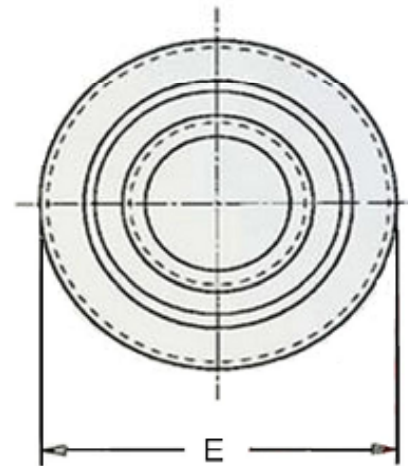

PCB-Pad Size Dimension

Stencil Masking Examples

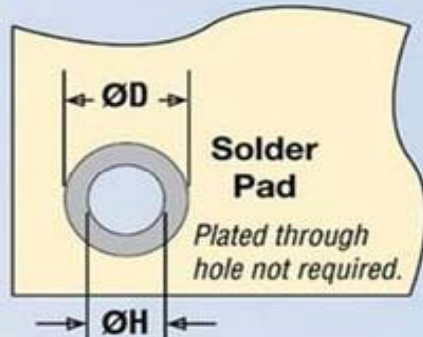

Tolerances unless otherwise specified (mm)

X	X.X	X.XX	X.XXX	Angle					
±	±	±	±	±3°					
DRW:	Jason	CHKD	Wilson	MATL:	Wilson	TOLERANCE	Mason	DATE	26.10.2018
APPD:	Schumi			FINISH	Jamy		Sheet No.		2 from 13

SMD Round Spacer Support M1,2

Part No.: **N45013**

Customer:

EDCON-COMPONENTS



Dimension of (mm)

Order Code	Thread	L ±0,13	A max.	C max.	E		H	Ø H Hole Size In PCB +0,08	Ø D Min. Solder Pad	MIN PCB Thickness
					Ref.	±0,13				
A01	M1,2 x 0,25	1,00	0,48	2,41	3,66	--	3,18	2,50	4,19	0,50
A02	M1,2 x 0,25	2,00	0,48	2,41	3,66	--	3,18	2,50	4,19	0,50
A03	M1,2 x 0,25	3,00	0,48	2,41	3,66	--	3,18	2,50	4,19	0,50
A04										
A05										
A06										
A07										
A08										
A09										
A10										
A11										
A12										
A13										
A14										
A15										
A16										
A17										
A18										
A19										
A20										
A21										
A22										
A23										
A24										
A25										
A26										
A27										

SMD Round Spacer Support M1,2	
Part No.:	N45013
Customer:	

DRW:	Jason	CHKD	Wilson	MATL:	Wilson	TOLERANCE	Mason	DATE	26.10.2018
APPD:	Schumi			FINISH	Jamy		Sheet No.		3 from 13

www.edcon-components.com

email: info@edcon-components.com

EDCON-COMPONENTS



Height of Thread	A	B	C	D	N	W1	W2	W3	W3	Pic Plac Mat.	PCS/Reel
	±2,0	min	±0,8	min	±2,0	±2,0	max.	min	max.		PCS
	330,00	1,50	13,00	20,20	60,00	24,40	30,40	23,90	27,40	Kapton-Film	1500
	330,00	1,50	13,00	20,20	60,00	24,40	30,40	23,90	27,40	Kapton-Film	1200
	330,00	1,50	13,00	20,20	60,00	24,40	30,40	23,90	27,40	Kapton-Film	1050
	330,00	1,50	13,00	20,20	60,00	24,40	30,40	23,90	27,40	Kapton-Film	950
	330,00	1,50	13,00	20,20	60,00	24,40	30,40	23,90	27,40	Kapton-Film	800
	330,00	1,50	13,00	20,20	60,00	24,40	30,40	23,90	27,40	Kapton-Film	800
	330,00	1,50	13,00	20,20	60,00	24,40	30,40	23,90	27,40	Kapton-Film	600
	330,00	1,50	13,00	20,20	60,00	24,40	30,40	23,90	27,40	Kapton-Film	600
	330,00	1,50	13,00	20,20	60,00	24,40	30,40	23,90	27,40	Kapton-Film	600
	330,00	1,50	13,00	20,20	60,00	24,40	30,40	23,90	27,40	Kapton-Film	500
	330,00	1,50	13,00	20,20	60,00	24,40	30,40	23,90	27,40	Kapton-Film	400
	330,00	1,50	13,00	20,20	60,00	24,40	30,40	23,90	27,40	Kapton-Film	400

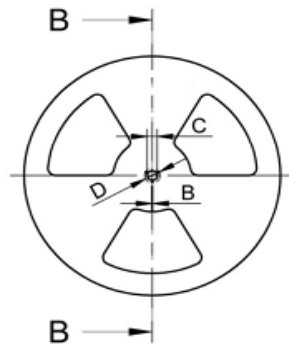
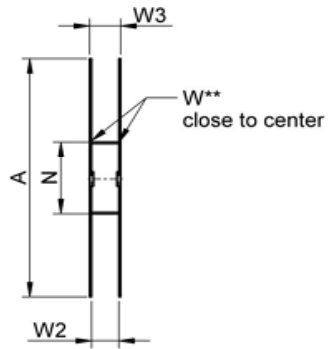

SMD Round Spacer Support M1,2	
Part No.:	N45013
Customer:	

DRW:	Jason	CHKD	Wilson	MATL:	Wilson	TOLERANCE	Mason	DATE	26.10.2018
APPD:	Schumi			FINISH	Jamy		Sheet No.		11 from 13

EDCON-COMPONENTS



Ordering Informations

Serie	Size Code	Thread Size	Material Code	Contact Plating	Special function	Special function	Special function	ROHS	Packing Code	
N45013	A01	M12	SS	TN	N	N	N	R	TR	

A01= Dimension look table	M12= Thread M1,2mm	BR= Brass	TN= Tin Plated	N= No function	N= No function	N= No function	R= ROHS Conform	BU= Bulk-Ware
		SS= Stainless Steel					N= NON ROHS Conform	
								TR= Tape Reel Packing

SMD Round Spacer Support M1,2	
Part No.:	N45013
Customer:	

DRW:	Jason	CHKD	Wilson	MATL:	Wilson	TOLERANCE	Mason	DATE	26.10.2018
APPD:	Schumi			FINISH	Jamy		Sheet No.		12 from 13

www.edcon-components.com

email: info@edcon-components.com



Soldering Profile Curve

Classification Reflow Profile (JEDEC J-STD-020C)

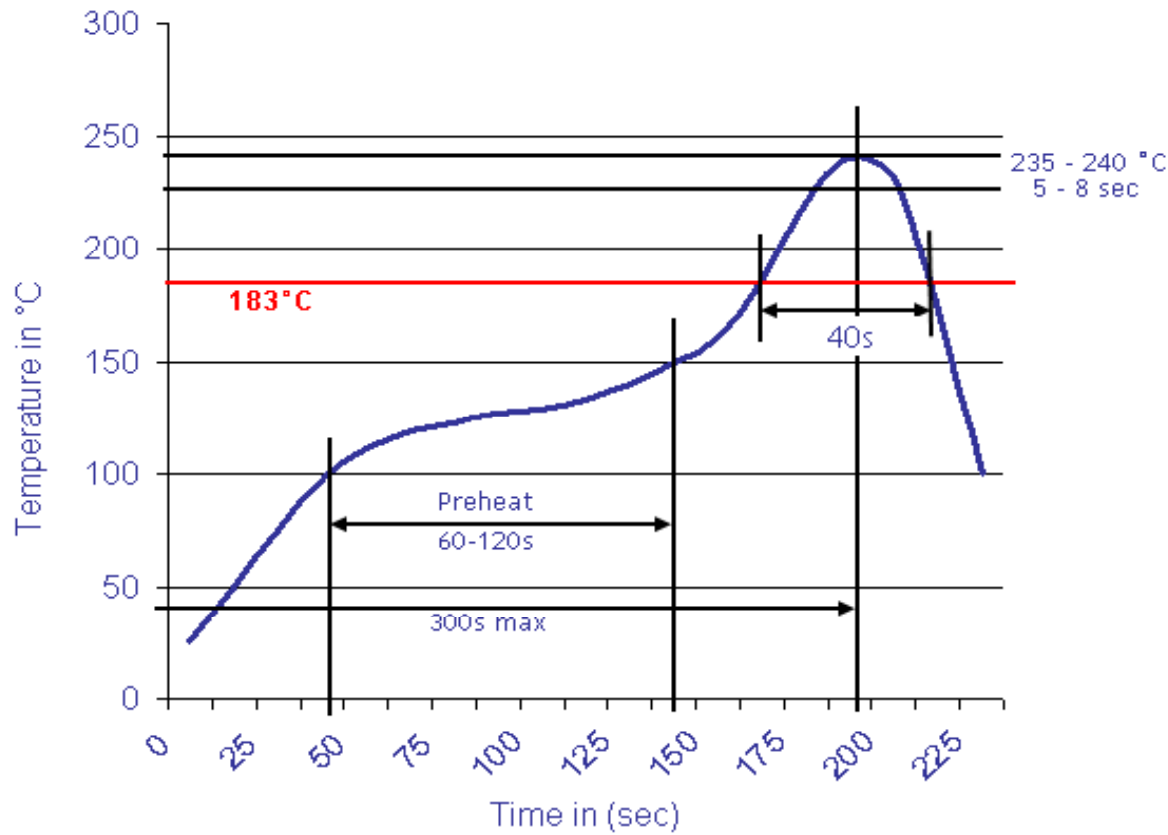

SMD Round Spacer Support M1,2	
Part No.:	N45013
Customer:	

DRW:	Jason	CHKD	Wilson	MATL:	Wilson	TOLERANCE	Mason	DATE	26.10.2018
APPD:	Schumi			FINISH	Jamy		Sheet No.		13 from 13