



DATA SHEET

SMD Round Spacer Support M2,0

Serie: N45006

**SMD Round Spacer
Support M2,0**

Serie No.: **N45006**

Customer:

DRW:	Jason	CHKD	Wilson	MATL:	Wilson	TOLERANCE	Mason	DATE	27.10.2018
APPD:	Schumi			FINISH	Jamy		Sheet No.		1 from 13

EDCON-COMPONENTS



Technical Informations

Thread Size	M2
Body Material	11SMnPb30
Surface:	Tin Plated
Torque:	0,2Nm
Solder Paste Thickness	150µm
Pic and Place Pad Mat.	KAPTON

Technical Dimensions (mm)

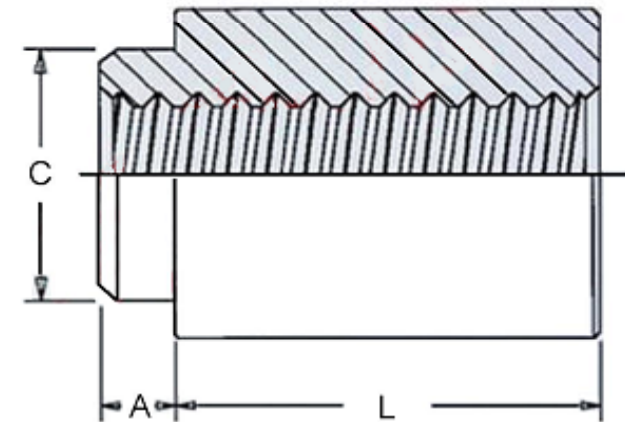
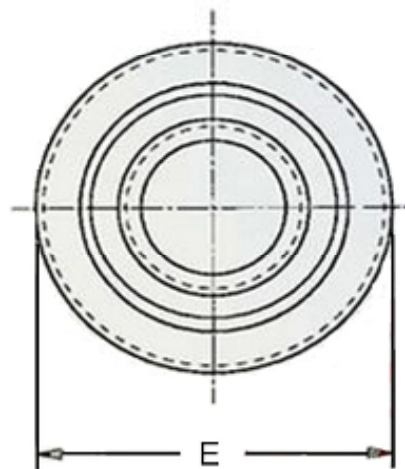

PCB-Pad Size Dimension

Stencil Masking Examples

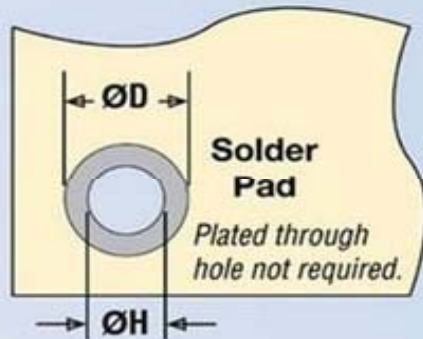

Tolerances unless otherwise specified (mm)

X	X.X	X.XX	X.XXX	Angle					
±	±	±	±	±3°					
DRW:	Jason	CHKD	Wilson	MATL:	Wilson	TOLERANCE	Mason	DATE	27.10.2018
APPD:	Schumi			FINISH	Jamy		Sheet No.		2 from 13

SMD Round Spacer Support M2,0

Part No.: **N45006**

Customer:

EDCON-COMPONENTS



Dimension of (mm)

Order Code	Thread	L ±0,13	A max.	C max.	E		H Nom.	Ø H Hole Size In PCB +0,08	Ø D Min. Solder Pad	MIN PCB Thickness
					Ref.	±0,13				
A01	M2 x 0,4	1,00	1,53	3,60	--	5,56	--	3,73	6,20	1,53
A02	M2 x 0,4	2,00	1,53	3,60	--	5,56	--	3,73	6,20	1,53
A03	M2 x 0,4	3,00	1,53	3,60	--	5,56	--	3,73	6,20	1,53
A04	M2 x 0,4	4,00	1,53	3,60	--	5,56	--	3,73	6,20	1,53
A05	M2 x 0,4	5,00	1,53	3,60	--	5,56	--	3,73	6,20	1,53
A06	M2 x 0,4	6,00	1,53	3,60	--	5,56	--	3,73	6,20	1,53
A07	M2 x 0,4	8,00	1,53	3,60	--	5,56	--	3,73	6,20	1,53
A08	M2 x 0,4	10,00	1,53	3,60	--	5,56	--	3,73	6,20	1,53
A09	M2 x 0,4	3,50	1,53	3,60	--	5,56	--	3,73	6,20	1,53
A10	M2 x 0,4	1,50	1,53	3,60	--	5,56	--	3,73	6,20	1,53
A11	M2 x 0,4	2,50	1,53	3,60	--	5,56	--	3,73	6,20	1,53
A12	M2 x 0,4	4,50	1,53	3,60	--	5,56	--	3,73	6,20	1,53
A13	M2 x 0,4	5,50	1,53	3,60	--	5,56	--	3,73	6,20	1,53
A14	M2 x 0,4	6,50	1,53	3,60	--	5,56	--	3,73	6,20	1,53
A15	M2 x 0,4	7,50	1,53	3,60	--	5,56	--	3,73	6,20	1,53
A16	M2 x 0,4	8,50	1,53	3,60	--	5,56	--	3,73	6,20	1,53
A17	M2 x 0,4	9,50	1,53	3,60	--	5,56	--	3,73	6,20	1,53
A18	M2 x 0,4	7,00	1,53	3,60	--	5,56	--	3,73	6,20	1,53
A19	M2 x 0,4	11,00	1,53	3,60	--	5,56	--	3,73	6,20	1,53
A20	M2 x 0,4	10,50	1,53	3,60	--	5,56	--	3,73	6,20	1,53
A21										
A22										
A23										
A24										
A25										
A26										
A27										

SMD Round Spacer Support M2,0	
Part No.:	N45006
Customer:	

DRW:	Jason	CHKD	Wilson	MATL:	Wilson	TOLERANCE	Mason	DATE	27.10.2018
APPD:	Schumi			FINISH	Jamy		Sheet No.		3 from 13

EDCON-COMPONENTS



Height of Thread	A	B	C	D	N	W1	W2	W3	W3	Pic Plac Mat.	PCS/Reel
	±2,0	min	±0,8	min	±2,0	±2,0	max.	min	max.		PCS
	330,00	1,50	13,00	20,20	60,00	24,40	30,40	23,90	27,40	Kapton-Film	1500
	330,00	1,50	13,00	20,20	60,00	24,40	30,40	23,90	27,40	Kapton-Film	1200
	330,00	1,50	13,00	20,20	60,00	24,40	30,40	23,90	27,40	Kapton-Film	1050
	330,00	1,50	13,00	20,20	60,00	24,40	30,40	23,90	27,40	Kapton-Film	950
	330,00	1,50	13,00	20,20	60,00	24,40	30,40	23,90	27,40	Kapton-Film	800
	330,00	1,50	13,00	20,20	60,00	24,40	30,40	23,90	27,40	Kapton-Film	800
	330,00	1,50	13,00	20,20	60,00	24,40	30,40	23,90	27,40	Kapton-Film	600
	330,00	1,50	13,00	20,20	60,00	24,40	30,40	23,90	27,40	Kapton-Film	600
	330,00	1,50	13,00	20,20	60,00	24,40	30,40	23,90	27,40	Kapton-Film	600
	330,00	1,50	13,00	20,20	60,00	24,40	30,40	23,90	27,40	Kapton-Film	500
	330,00	1,50	13,00	20,20	60,00	24,40	30,40	23,90	27,40	Kapton-Film	400
	330,00	1,50	13,00	20,20	60,00	24,40	30,40	23,90	27,40	Kapton-Film	400

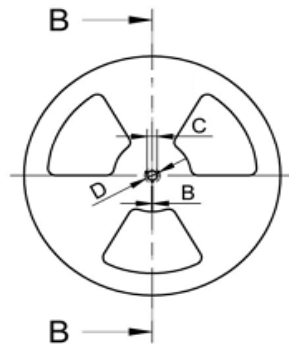
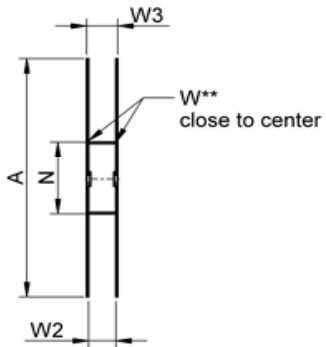

SMD Round Spacer Support M2,0

Part No.: **N45006**

DRW:	Jason	CHKD	Wilson	MATL:	Wilson	TOLERANCE	Mason	DATE	27.10.2018
APPD:	Schumi			FINISH	Jamy		Sheet No.	11 from 13	

Customer:

EDCON-COMPONENTS



Ordering Informations

Serie	Size Code	Thread Size	Material Code	Contact Plating	Special function	Special function	Special function	ROHS	Packing Code
N45006	A01	M20	SS	TN	N	N	N	R	TR

A01= Dimension look table	M20= Thread M2,0mm	BR= Brass	TN= Tin Plated	N= No function	N= No function	N= No function	R= ROHS Conform	BU= Bulk-Ware
		SS= Stainless Steel					N= NON ROHS Conform	
								TR= Tape Reel Packing

SMD Round Spacer Support M2,0	
Part No.:	N45006
Customer:	

DRW:	Jason	CHKD	Wilson	MATL:	Wilson	TOLERANCE	Mason	DATE	27.10.2018
APPD:	Schumi			FINISH	Jamy		Sheet No.	12 from 13	

www.edcon-components.com

email: info@edcon-components.com



Soldering Profile Curve

Classification Reflow Profile (JEDEC J-STD-020C)

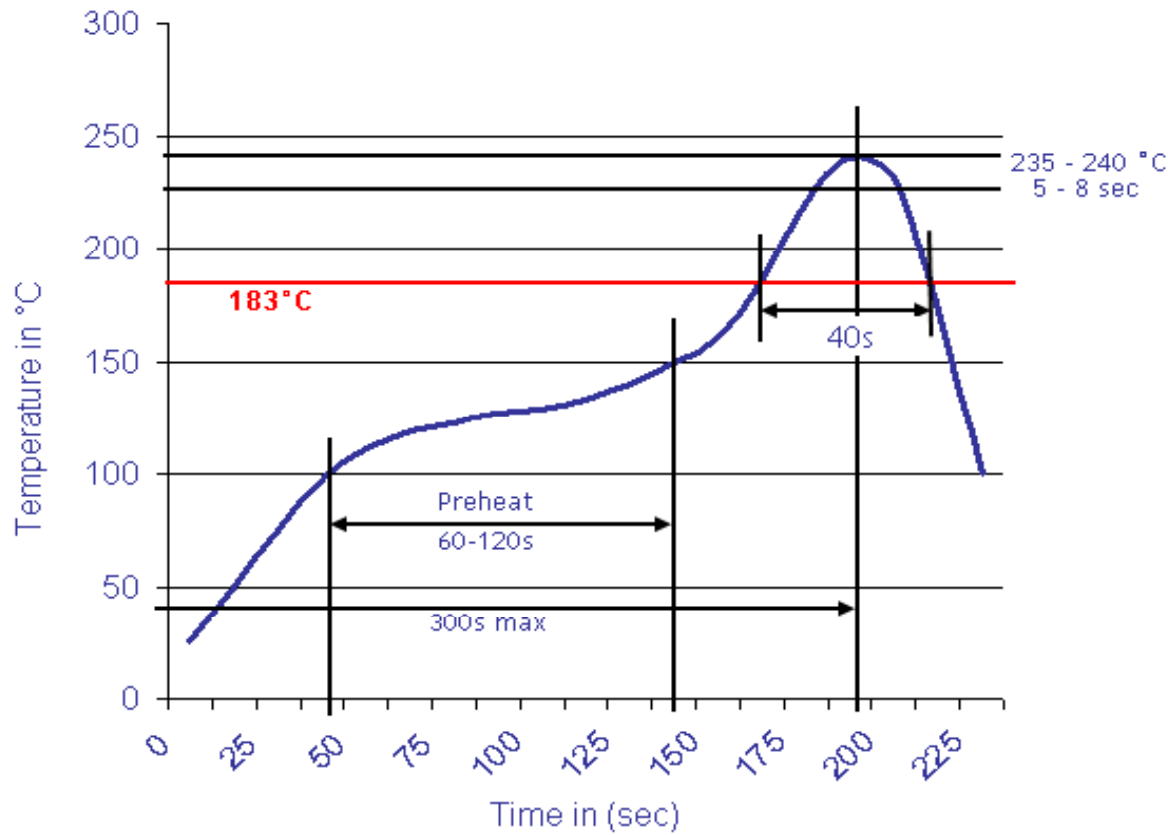

SMD Round Spacer Support M2,0	
Part No.:	N45006
Customer:	

DRW:	Jason	CHKD	Wilson	MATL:	Wilson	TOLERANCE	Mason	DATE	27.10.2018
APPD:	Schumi			FINISH	Jamy		Sheet No.		13 from 13