

# EDCON-COMPONENTS



## Technical Description

Mode of action: Self Tapping Screw  
 Size: M2,3  
 Screw Specification: 0,2

Head Type: Head Slotted Countersunk  
 Steel Grade: 4,8  
 Thread Tol.: ± 0,05mm  
 Material: Stainless Steel  
 Surface of Thread: Nickel Plated

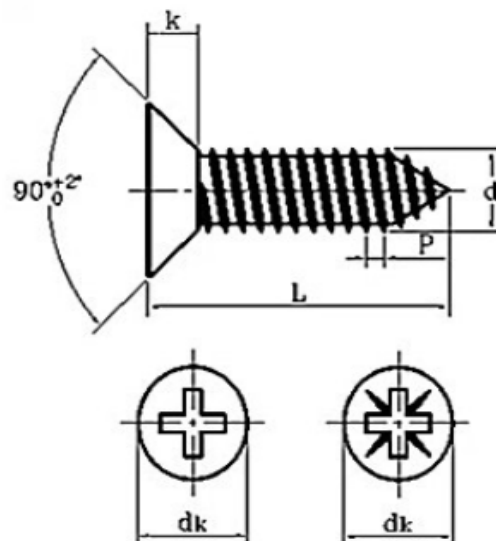

|       |     |    |
|-------|-----|----|
| d     | 2,3 | mm |
| dk    | 4,2 | mm |
| k     | 1,5 | mm |
| Angle | 90° |    |

## Screw Length Order Code Table

| Code | Length |    |
|------|--------|----|
| A01  | 4,0    | mm |
| A02  | 5,0    | mm |
| A03  | 6,0    | mm |
| A04  | 8,0    | mm |
| A05  | 10,0   | mm |
| A06  | 12,0   | mm |
| A07  | 14,0   | mm |
| A08  | 16,0   | mm |
| A09  | 18,0   | mm |
| A10  | 20,0   | mm |
| A11  |        | mm |
| A12  |        | mm |
| A13  |        | mm |
| A14  |        | mm |
| A15  |        | mm |
| A16  |        | mm |
| A17  |        | mm |
| A18  |        | mm |
| A19  |        | mm |
| A20  |        | mm |

| Serie | Length Code | Material | Surface Treatment | Color of Screw | ROHS | Packing |
|-------|-------------|----------|-------------------|----------------|------|---------|
|-------|-------------|----------|-------------------|----------------|------|---------|

|        |   |     |     |    |    |   |    |
|--------|---|-----|-----|----|----|---|----|
| N48017 | - | A01 | S48 | NI | 00 | R | BU |
|--------|---|-----|-----|----|----|---|----|

|                            |                               |                   |                                 |                     |                        |
|----------------------------|-------------------------------|-------------------|---------------------------------|---------------------|------------------------|
| Axx= Look order code Table | S48= Steel Material Grade 4,8 | NI= Nickel Plated | 00= surfaced Colored (Standard) | R= ROHS Conform     | BU= Bulk-Ware          |
|                            |                               |                   | BK= black colored               | N= NON ROHS Conform | IV= Individual Package |

**Self-Tapping Screw Size M2,3**

Part No.: **N48017**

|       |        |      |        |        |        |           |           |      |            |
|-------|--------|------|--------|--------|--------|-----------|-----------|------|------------|
| DRW:  | Jason  | CHKD | Wilson | MATL:  | Wilson | TOLERANCE | Mason     | DATE | 27.10.2015 |
| APPD: | Schumi |      |        | FINISH | Jamy   |           | Sheet No. |      | 1 from 1   |

Customer: \_\_\_\_\_  
 email: info@edcon-components.com