



## Technical Description of Varistor

### „N“ Series Low, Medium and High Low Voltage Varistor

Compared with the GB product in the same specification, our „N“ series zinc oxide varistor, which is produced with new formula and technique, is improved in terms of maximum peak current and maximum energy, so as to be more reliable.

#### Features

Maximum Peak current: Superior to GB standard by 2.4-3.9 times.

Max. Energy: Superior to GB standard by 1.5-2 times.

Varistor voltage 18-68V (+- 10%)

Low clamping voltage for better surge absorption

Excellent response, Absorbing high frequency surge puls

Symmetry of V-I applicable to indirect-circuit.

Varistor voltage: 82-1800V (+-10%), wide products range for surge protection on AC 100V to AC 480V nominal system.

#### Recommended Applications

Transistor, diode, IC, thyristor or triac semiconductor protection.

Surge protection in consumer electronics

Surge protection in communication, measuring or controller instrument.

Relay or electromagnetic valve surge absorption

#### Precautions

The varistor shall not be operated beyond the specified „Ratings“ and „Environmental Conditions“ in the Catalog or the Specifications to prevent them from deterioration, breakdown, flaming or glowing. Following „Precautions for Safety“ and „Application Notes“ shall be taken in your major consideration.

#### Precautions for Safety

The temperature of the working environment of the varistor must fall in the range required by technical

The varistor shall not be operated exceeding the specified „Maximum Allowable Voltage“ in the Catalog or the Specification.

In case of application to repeated surge/overvoltages, the varistor shall not be subjected to surge currents and energy levels above the specified maximum ratings in „Pulse Lifetime Rating“ in the Catalog or the Specifications.

When surge/overvoltages are intermittently applied to the varistor with short durations, the devices shall not be operated beyond the specified „Rated Power“ in the Catalog or the Specification.

The varistor shall not be operated beyond the „Maximum Peak Current Ratings“ in the Catalog.

It is recommended that the varistor shall be located 3mm away from other heatgenerating or combustible components.

#### Warning

When the varistor are applied between a live part and a metallic chassis of equipment, following safety countermeasures shall be taken to protect human from electric shock.

The metallic chassis shall be earthed to the ground.

A protective device against electric leakage must be installed in the equipment, or alternatively, a thermal tie fuse should be attached closely to the varistor and seriesconnected within its circuit.

The live part shall be equipped with a protective cover for preventing electric shock.

#### Applicative Notes

Protective Devices for varistors

Precaution measures are to be taken against the accident damage.

In case of „Across the Line Use“, the varistor shall be protected by connecting a ground fault circuit interrupter or fusing in series to the devices (see Figure 1)

In case of „Line to Ground Use“, the short-circuit of the varistor may not blow the current type fuse due to the grounding resistance (Between Line and Ground).

Which may cause flaming or burnout of the devices in the worst case. Following safety countermeasures (A or B) are recommended.

Connecting a „leakage current circuit breaker“ in series to the varistor to be protected.

Use current type fuses and a thermal type fuse which are thermally coupled with the varistor each other (See Figure 1)

#### Selection of Varistor Voltage Rating

General Precautions

In selection of Varistor Voltage Rating for line protection, following general precautions shall be taken in your consideration.

A Maximum operating voltage shall be lower than the specified „Maximum Allowable voltage“ of the varistor applied.

#### Radial Varistor Size 7mm

Part No.: **W11002-820x**

Customer:

DRW:	Jason	CHKD	Jules	MATL:	Wu	DATE	06.06.2008
APPD:	Join			FINISH	Shieh	Sheet	1 from 8



### Technical Discription of Varistor

B In selection of the varistor reasonable margin is required against fluctuation of the primary line (or circuit) voltage. Special consideration must be given to load unbalance of separately wired loads, short circuit between the live line and the neutral line or LC resonance at switching for a capacitive or inductive load.

Across-the-Line Use (Line to Line Surge Protection)  
Select the varistor recommended in Table 1

**Notes:**

For some electric equipments working under the phase voltage, the endurance of the short-time line voltage shall be taken into consideration during the design, and for such case, please select the varistor with “\*”.

Line to Ground Use (Line to Ground Surge Protection)  
select the varistor recommended in Table 1.

**Selection of Fuse Ratings**

The recommended fuse locations are shown in Figure 1. For varistor protection, it is recommended to select suitable fuse in Table 2.

**Enviromental Conditions**

The varistor shall not be exposed outdoors,because of being designed for indoor use.

The varistor shall not be operated beyond the Specified Operating Temperature Range and shall not be exposed to direct sunlight and heating part of equipment.

The varistor shall not be operated under severe conditions of high temperatures and high humidities such as places exposed to rain, wind and vapour.

The varistor shall be free from dust, salty wind and atomospheres polluted by corrosive gas.

**Precautions for Assemblies and Handlings**

Organic solvents such as thinner and acetone etc, shall not be applied to varistor for preventing deterioration of external coating or molding resin.

Abnormal mechanical stresses beyond the specified values forces, shall be kept minimum to prevent electrical failures of the devices.

**Long Term Storage**

The varistor shall not be stored under severe conditions of high temperatures and high humidities. Store them indoors under 40°C max and 75% RH max. Use them within one year, if stored beyond the limit, check the solderbility before use.

The varistor shall not be stored under corrosive atmospheres such as hydrogen sulphide,sulphurous acid, chlorine and ammonia.

The varistor shall not be exposed to direct sunlight and shall not be stored under dew formation.

**Parallel Capacitance of the Varistors**

The Parallel Capacitance of the Varistor is listed in the specification Table, for the designer Reference in high frequency circuit.

Table 1			
Lini-Line Surge Protechtion		Line Ground Surge Protection	
Nominal Line Voltage	Serie of Varistor	Nominal Line Voltage	Serie of Varistor
AC100V	W1100x 271	AC100V	W1100x 821K
AC120V	W1100x 331	AC120V	W1100x 821K
AC220V	W1100x 471	AC220V	W1100x 182K
	W1100x 511		
	W1100x 561		
	W1100x 681		
AC380V	W1100x 821	AC380V	W1100x 182K
	W1100x 911		

Table 2					
Varistor Size	5mm	7mm	10mm	14mm	20mm
Recommend Fuse Ratingsd	1-2 A	2-4A	3-5A	4-8A	6-10A

<b>Radial Varistor Size 7mm</b>	
Part No.:	<b>W11002-820x</b>
Customer:	

DRW:	Jason	CHKD	Jules	MATL:	Wu	DATE	06.06.2008
APPD:	Join			FINISH	Shieh	Sheet	2 from 8



**Technical Discription of Varistor**

**Line-Line Surge Protection**

**Line-Ground Surge Protection**

**Figure 1**

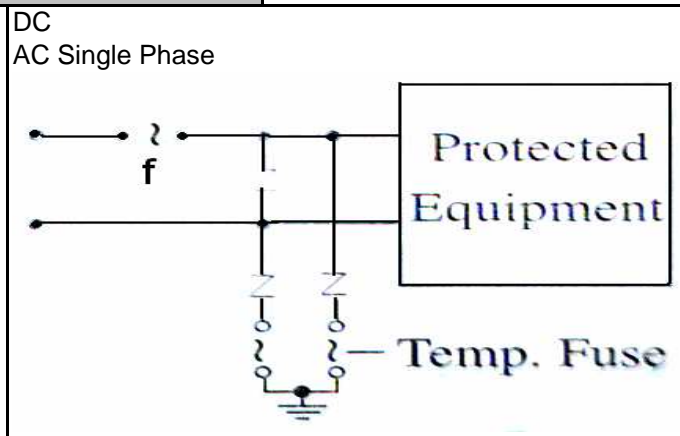
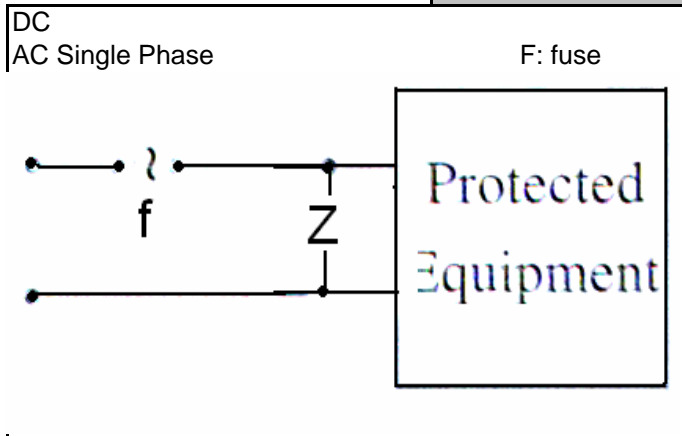

**Technical Data**

In the following experiments, all the characteristics, are experimented and obtained in compliance with the method and termsd of GB/T 10194-GB/T 10195-1997 idt IEC 1052-2: 1991 QC 420100 specified indoor temperature: +25°C +/- 5°C, comparative humidity: 45-85%, Atmospheric pressure: 86-106KPa.

Characteristics	Test Methods	Specifications
Varistor Voltage	The voltage between two leads of the varistor which is measured under the sprcified current, 7mm series specified current: 0,1mA, / 9 -23mm series specified current : 1mA	To meet the specified value
Maximum Allowable Voltage	The voltage between two leads of the varistor which is measured under the sprcified current, 7mm series specified current: 0,1mA, / 9 -23mm series specified current : 1mA	

<b>Radial Varistor Size 7mm</b>	
Part No.:	<b>W11002-820x</b>
Customer:	

DRW:	Jason	CHKD	Jules	MATL:	Wu	DATE	06.06.2008
APPD:	Join			FINISH	Shieh	Sheet	3 from 8



### Technical Discription of Varistor

Leackage Current	The current value passing the varistor at the maximum allowable DC voltage at 25°C		$V_c \leq 68V$ $I \leq 40\mu A$	
Clamping Voltage	The maximum Voltage between two terminals with the specified standard impulse current (8x20μs) illustrated below applied.			
Rated Power	The maximum power that can be applied within the specified ambient temperature.			
Maximum Energy	Maximum energy from one or a burst of pulse. It is the value within the varistor voltage change of +/- 10% when one impulse of 10x1000μs or 2ms is applied.		To meet the specified value (better than GB/T 10194-GB/T10195-1997 and DJ/T10348-10349-93)	
Maximum Peak current	1 time	The maximum current within the varistor voltage change of +/-10% when a single standard impulse current of 8 x 20μs is applied.	To meet the special value ( better than GB/T10194-GB/T10195- 1997 and SJ/T10348-10349-93)	
	2 times	The maximum current within the varistor voltage change of +/-10% when a single standard impulse current of 8 x 20μs is applied two times with an interval of 5 minutes.		
Temperature Coefficient of varistor voltage	$\frac{V_c (+85^\circ C) - V_c (+25^\circ C)}{V_c (+25^\circ C)} \times 100\%$		0 ~ -0,05%/°C	
Capacitance	Testing Condition: 1KHz +/-10%, 1Vrms.(1Mhz +/- 10% below 100pf		To meet the specified value	
Insulation Strength ( Body Insulation)	The specified voltage shall be applied between both terminals of the specimen connected together and metal foil closely wrapped round ist body for 1 minute.		No breackdown	
	Varistor Voltage	Testing Voltage (AC)		
	VC ≤ 330V	1000Vrms		
VC ≥ 330V	2000Vrms			
Impulse Life	The change of Vc shall be measured after the impulse current listed in "Pulse Lifetime Ratings" with the interval of 2min when 10~100 impulses are applied or the 10 second interval when 10000-1000000 impulses are applied.		$\Delta V_c/V_c < +/-10\%$ (better than GB/T10194-GB/T10195-1997 and SJ/T10348-10349-93)	
Termnial Pull strength	After graually applying the load specified below and keeping the load fixed for 10 seconds, the change shall be measured and meet the requirement with no outstanding damage.		No Outstanding Damage	
	Terminal	Diameter		Fore
	Ø 0,6mm	Ø 0,8mm		5N
	Ø 1,0mm			10N

#### Radial Varistor Size 7mm

Part No.: **W11002-820x**

Customer:

DRW:	Jason	CHKD	Jules	MATL:	Wu	DATE	06.06.2008
APPD:	Join			FINISH	Shieh	Sheet	4 from 8



### Technical Discription of Varistor

Terminal Bending Strength	The unit shall be secured with ist terminal kept vertical and the weight specified below be applied in the axial direction. The terminal shall gradually be bent by 90° in one direction. Then 90° in the opp side direction, and again back to the original position. The change shall be measured and meet the requirement with no outstanding damage.					No Outstanding Damage	
	Terminal		Diameter		Fore		
	Ø 0,6mm		Ø 0,8mm		5N		
	Ø 1,0mm				10N		
Vibration	Subjected to simple harmonic motion of 0,75mm amplitude 1,5nm maximum total excursion between limits of 10-55Hz. Frequency scan shall be traversed in one minute. This motion shall then be applied for period of two hours in each of three mutually perpendicular directions.. The change shall be measured and meet the requirement with no outstanding damage.					No Outstanding damage	
Solderability	After dipping the terminal to a depth of approximately 2mm from the body in a soldering bath of 235 +/-5°C for 2 +/- 0,5 sec. The termination shall be uniformly tinned.					Approximate 95% of the terminals shall be covered with new solder uniformly	
Resistance to Soldering Heat	The terminal shall be dipped into a soldering bth with temperature of 260° +/-5°C to a point of 2-2,5mm from the body for 10 +/- 1sec. Size 7mm shall be 5 +/- 1sec. ). And then stored at room temeprature and humidity for 1-2 hours. The change shall be measured and meet the requirement with no outstanding damage.					Δ Vc/Vc < +/-5% NO Outstanding Damage	
High Temperature Storage / Dry Heat	The specimen shall be subjected to 125 +/-2°C for 10 00hours in a drying oven without load and then stored at room temperature and humidity for 1.2 hours. The change of Vc shall be measured and meet the requirement with no outstanding damage.					Δ Vc/Vc < +/-5%	
Humidity	The specimen shall be subjected to 40°C, 90 to 95% R.H. for 1000 hours without load and then stored at room temperature for 1-2 hours. The change of Vc shall be measured and meet the requiremnt with no outstanding damage.					Δ Vc/Vc < +/-5%	
Temperatur Cycle	Temeprature cycle operation of the following table shall be repared 5 times continuously. And the nth specimen shall be left at room ambient for 1-2 hours. The change of Vc shall be measured and meet the requirement with no outstanding damage.					Δ Vc/Vc < +/-5% No Outstanding Damage	
	Steps	Temperature (°C)	Time (min)	Steps	Temperature (°C)		Time (min)
	1		30 +/- 3	3	+125 +/-2		30 +/-3
	2	Room temperature	15 +/- 3	4	Room temperature		15 +/-3
High Temperature Load/Dry Heat Load	After being continuously applied the maximum allowable voltage at 85 +/-2°C for 1000hours, the specimen shall be stored at room temperature and humidity for 1-2 hours. The change shall be measured and mmet the requirement with no outstanding damage.					Δ Vc/Vc < +/-10%	

#### Radial Varistor Size 7mm

Part No.: **W11002-820x**

Customer:

DRW:	Jason	CHKD	Jules	MATL:	Wu	DATE	06.06.2008
APPD:	Join			FINISH	Shieh	Sheet	5 from 8



### Technical Discription of Varistor

Damp Heat Load / Humidity Load	After being continuously applied the maximum allowable voltage at 40 +/-2°C, 90-95% R.H. for 1000hours, the specimen shall be stored at room temperature and humidity for 1-2 hours. The change of Vc shall be measured and meet the requirement with no outstanding damage.	$\Delta V_c/V_c < +/-10\%$
Low Temperature Storage/Cold	Specimen shall be subjected to an ambient of -40 +/-2°C for 1000hours. And after the specimen shall be left at room ambient for 1-2 hours. The change of Vc shall be measured and meet the requirement with no outstanding damage.	$\Delta V_c/V_c < +/-5\%$

### Components Specification

Construction / Surface . The product surface should not be damaged or grinded.. The marking should be legible.

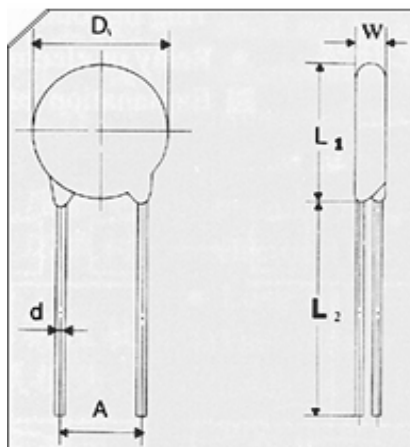

all dimensions in mm						
Range	Dmax.	Wmax.	A	L1max.	L2	d
7mm 180K ~ 680K	9,0	5,2	5.0 +/-1.0	12,2	20,0	0,6
7mm 820K ~ 511K	9,0	6,2	5.0 +/-1.0	12,2	20,0	0,6

#### Marking

Edcon Components product "NAME" , type code, and nominal voltage. and Safety Certificate

This part No., has been approved by CQC, the file No. is CQC 02001002448, by UL the File No. is E203745 and by VDE, the file No. 40008571

No.	Parameter	Specifications	Test conditions
2,1	Maximum allowable voltage	<b>AC: 50Vrms DC: 65V</b>	
2,2	Average power dissipation	<b>≥ 0,25W</b>	
2,3	Varistor voltage	<b>82V (74~90) +/-10%</b>	Test current: 1mA DC
2,4	Clamping voltage	<b>≤ 135V</b>	Test waveform: 8/20μs <b>Test current: 10A</b>
2,5	Maximum surge current	<b>≥ 1750A 1 time</b> <b>≥ 1250A 2 times</b>	Test waveform :8/20μs Interval between two surges: 5min.
2,6	Energy absorption	<b>≥ 7,0 J</b> <b>≥ 5,0 J</b>	Test waveform : 10/1000μs Test waveform : 2ms
2,7	Temperature coefficient of varistor voltage	<b>. +0,05% ~ 0,05% /°C</b>	Temperature range: +25°C ~ +85°C
2,8	Capacitance	<b>≤ 810pf</b>	Test frequency: 1KHz

#### Radial Varistor Size 7mm

Part No.: **W11002-820x**

Customer:

DRW:	Jason	CHKD	Jules	MATL:	Wu	DATE	06.06.2008
APPD:	Join			FINISH	Shieh	Sheet	6 from 8

Copyright by EDCON-COMPONENTS H.Schmitt 20.6.2008



**Components Specification**

No.	Parameter	Specifications	Test conditions
2,9	Dissipation factor tangent value	$\leq 0,1$	Test frequency: 1KHz
2,10	Withstanding voltage ( Body insulation)	No breakdown	Test voltage: 2500Vrms Test time: 1min.

**Mechanical Characteristics**

No.	Parameter	Specifications	Parameter	Terminal diameter	Force	Operating conditions
3,1	Robustness of termination ( Tensile)	No remarkable mechanical damage	Tensile	$\varnothing 0,8$	9,8N	10seconds
3,2	Robustness of termination ( Bending)	No remarkable mechanical damage	Bending	$\varnothing 0,8$	4,9N	3 times
3,3	Vibration	No remarkable mechanical damage	repeatedly applying a single harmonic vibration (amplitude: 0,75mm) with 1 minute vibration frequency cycles (10Hz to 55Hz, to 10Hz) to each of three perpendicular for 2 hours			
3,4	Solderability	Approximately 95% of the terminals should be covered with new solder uniformly	Dipping the terminals to a depth of approximately 3mm from the body in a soldering bath of 235 +/-5°C for 2 +/- 0,5sec.			
3,5	Resistance to soldering heat		Dipping the terminals to a depth of approximately 2mm from the body in a soldering bath of 260 +/-5°C for 10 +/- 1sec.			

**Environmental characteristics**

No.	Parameter	Specifications	Test conditions
4.1	High temperature storage	$\Delta V 1mA / V1mA \leq +/- 5\%$	Temperature: 125 +/-2°C Time: 1000hours
4.2	Humidity storage	$\Delta V 1mA / V1mA \leq +/- 5\%$	Temperature: 40 +/-2°C Humidity: 90 to 95%RH Time: 1000hours
4.3	Low temperature storage	$\Delta V 1mA / V1mA \leq +/- 5\%$	Temperature: -40 +/-2°C Time: 1000hours
4.4	Temperature cycle	$\Delta V 1mA / V1mA \leq +/- 5\%$ No remarkable mechanical damage	step
			temperature
			time
			1
			30min.
2	Room temperatur	3min.	
3		30min.	
4	Room temperatur	3min.	
			Repeating above cycle 5 times
4.5	High Temperature load	$\Delta V 1mA / V1mA \leq +/- 10\%$	Temperature: +85 +/-2°C Time: 100hours Voltage 420Vrms
4.6	Damp heat load	$\Delta V 1mA / V1mA \leq +/- 10\%$	According to IEC 68-2-3 test Ca Voltage: DC 560V + 10% Time: 96 hours
4.7	Impulse life I (140Ax10 4 times)	$\Delta V 1mA / V1mA \leq +/- 10\%$	Impulse waveform : 8/20µs Interval between pulses: 10sec
4.8	Impulse life II (70Ax10 4 times)	$\Delta V 1mA / V1mA \leq +/- 10\%$	Impulse waveform : 8/20µs Interval between pulses: 10sec

Operating temperature range . -40 to +85°C

**Radial Varistor Size 7mm**

Storage temperature range . -40 to 125°C

Part No.: **W11002-820x**

Customer:

DRW:	Jason	CHKD	Jules	MATL:	Wu	DATE	06.06.2008
APPD:	Join			FINISH	Shieh	Sheet	7 from 8



**Soldering Characteristics**

**Soldering Profile for Lead Soldering**



**Soldering Profile for Lead Free Soldering**



**Ordering Information**

Serie	Range	Tolerance	ROHS	Packing		
W11002	820	M	R	BU		
	820= 82V	M= 20%	R= ROHS conform	BU= Bulk-Ware		
		K= 10%	N= NON conform	TR= Tape / Reel		

**Radial Varistor Size 7mm**

Part No.: **W11002-820x**

Customer:

DRW:	Jason	CHKD	Jules	MATL:	Wu	DATE	06.06.2008
APPD:	Join			FINISH	Shieh	Sheet	8 from 8