

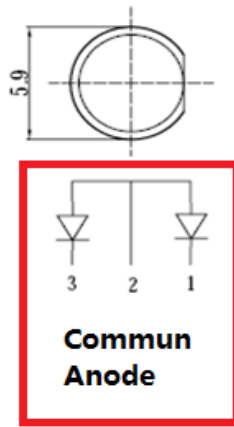

**Applications**

- Electronic Signs and Signals
- Small Area Illuminations
  - Back Lighting
  - Other Lighting

**Technical Drawing**

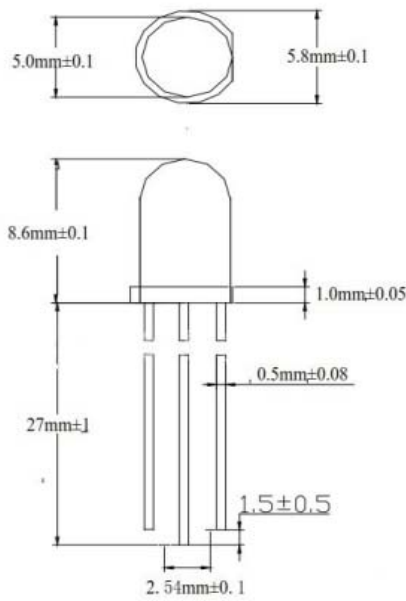

2. Common Anode  
 1, 3. Cathode

**Notes :**

All dimensions in mm tolerance is  $\pm 0.1$ mm unless otherwise noted.

<b>Round LED</b>	
<b>Red</b>	<b>Yellow Green</b>
Part No.:	<b>M13J1008</b>
Customer:	

DRW:	Ron	CHKD	Lang	MATL:	Chang	DATE	29.11.2018
APPD:	Xie			FINISH	Wang	Sheet	1 from 6



**Absolute Maximum Ratings**

Item	Symbol	---	---	Unit
Power Dissipation	P <sub>D</sub>	78	78	mW
DC Forward Current	I <sub>F</sub>	30	30	mA
Pulsed Forward Current	I <sub>FP</sub> *	100	100	mA
Reverse Voltage	V <sub>R</sub>	5		V
Operating Temperature	T <sub>OP</sub>	-30 to 85		°C
Storage Temperature	T <sub>ST</sub>	-40 to 100		°C

\* 0.1 msec pulse, 10% duty cycle

**Electrcal / Optical Characteristics**

Ermitting Color	Red		Yellow Green	
Material	---		---	
Forward Voltage	typ.	2.1	2.1	V <sub>F</sub>
	max.	2.6	2.6	V <sub>F</sub>
Wavelength typ.	λ <sub>D</sub>	620	565	nm
	λ <sub>P</sub>	625	570	nm
	Δλ	---	---	nm
Color Temperature	min.	---	---	K
	max.	---	---	K
Luminous Intensity *	min.	500	330	mcd
	typ.	750	550	mcd
Reverse Current	max.	10		μA
Viewing Angle	2θ <sub>1/2</sub>	60		

\* Per NIST standards

<b>Round LED</b>	
<b>Red</b>	<b>Yellow Green</b>
Part No.:	<b>M13J1008</b>
Customer:	

DRW:	Ron	CHKD	Lang	MATL:	Chang	DATE	29.11.2018
APPD:	Xie			FINISH	Wang	Sheet	2 from 6



<b>Round LED</b>	
<b>Red</b>	<b>Yellow Green</b>
Part No.:	<b>M13J1008</b>
Customer:	

DRW:	Ron	CHKD	Lang	MATL:	Chang	DATE	29.11.2018
APPD:	Xie			FINISH	Wang	Sheet	3 from 6



**Typical Characteristics**

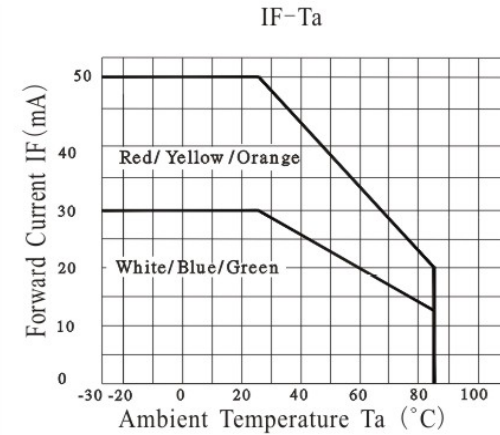
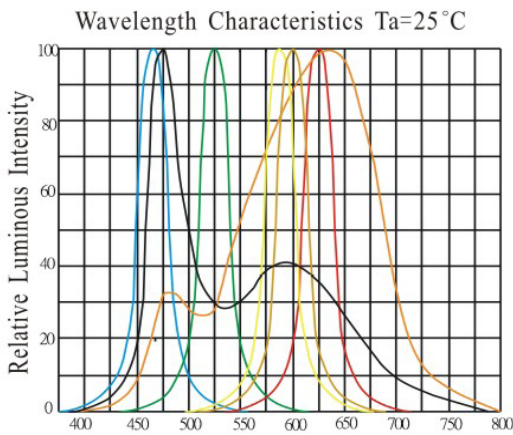
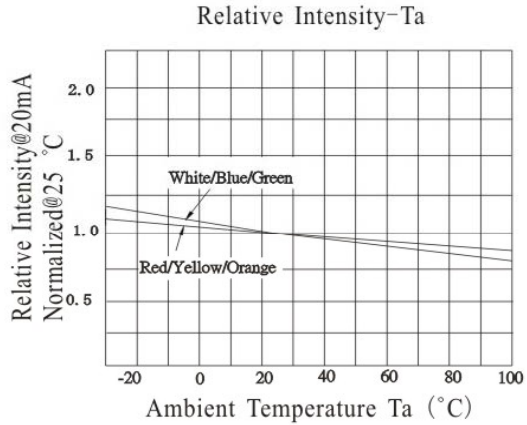
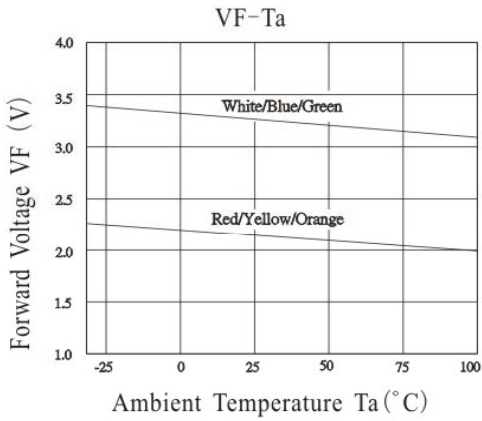
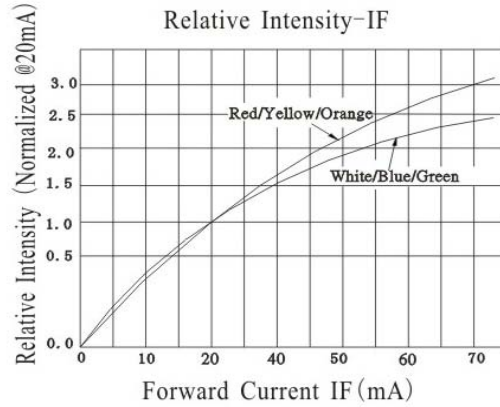
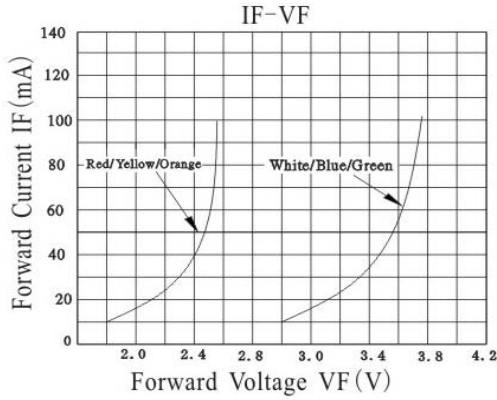

<b>Round LED</b>	
<b>Red</b>	<b>Yellow Green</b>
Part No.:	<b>M13J1008</b>
Customer:	

DRW:	Ron	CHKD	Lang	MATL:	Chang	DATE	29.11.2018
APPD:	Xie			FINISH	Wang	Sheet	4 from 6



**Solder Condition**

**Lead Free Solder**

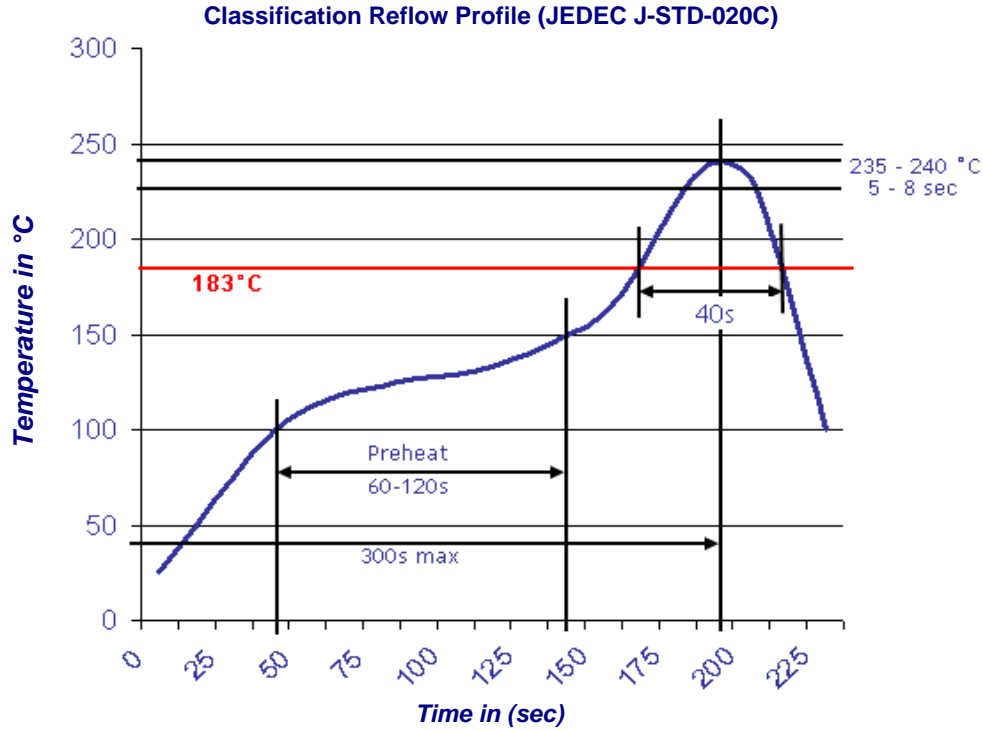

<b>Round LED</b>	
<b>Red</b>	<b>Yellow Green</b>
Part No.:	<b>M13J1008</b>
Customer:	

DRW:	Ron	CHKD	Lang	MATL:	Chang	DATE	29.11.2018
APPD:	Xie			FINISH	Wang	Sheet	5 from 6



**Color table curve**

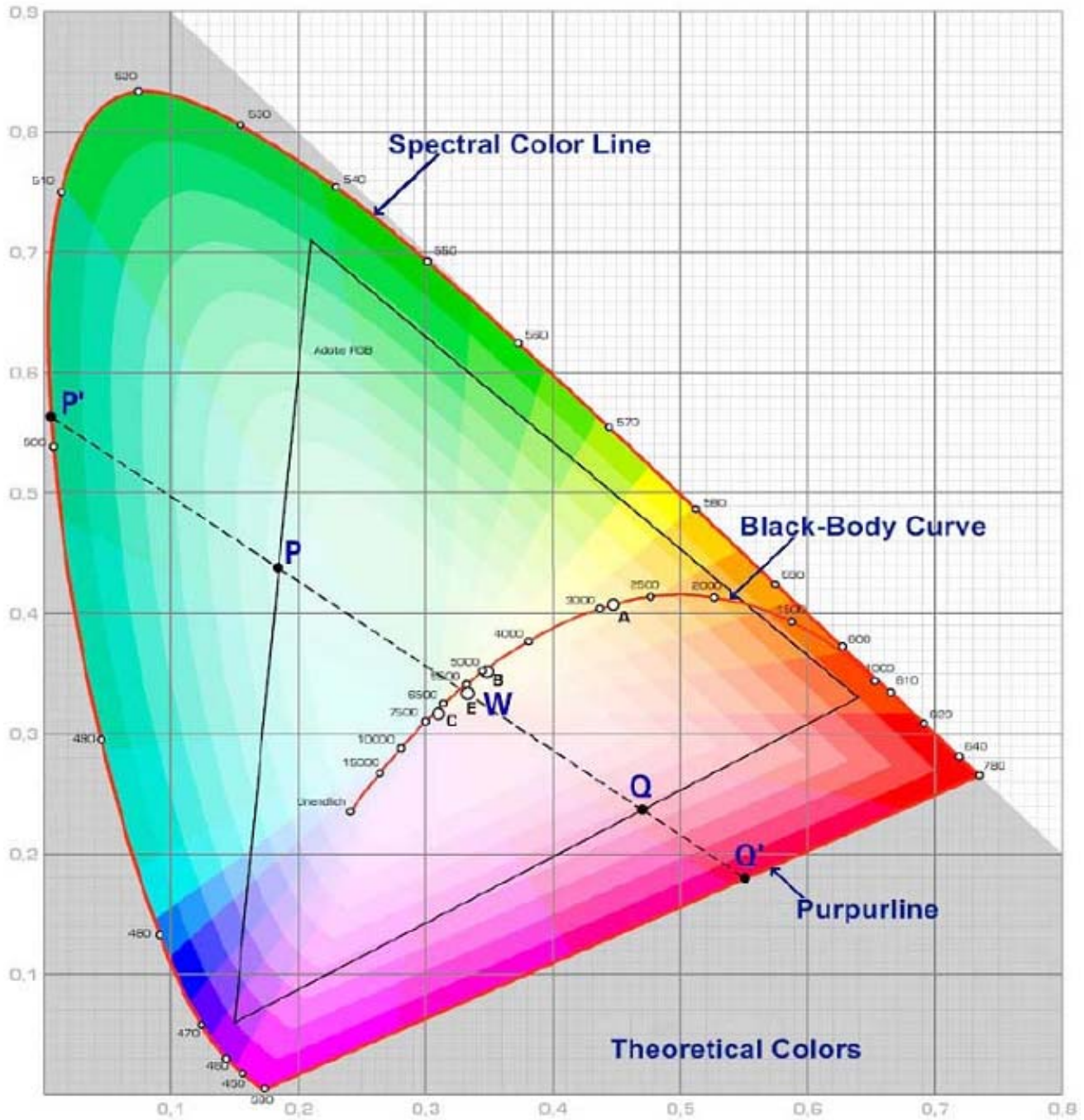

<b>Round LED</b>	
<b>Red</b>	<b>Yellow Green</b>
Part No.:	<b>M13J1008</b>
Customer:	

DRW:	Ron	CHKD	Lang	MATL:	Chang	DATE	29.11.2018
APPD:	Xie			FINISH	Wang	Sheet	6 from 6