

EDCON-COMPONENTS



Specifications

Current Rating:	3 Ampere
Insulator Resistance:	5000 Megaohm min.
Contact Resistance	20m Ohm max.
Dielectric Withstanding:	AC 500V
Operating Temperature:	-.65°C to +125°C
Contact Material:	Brass
Insulator Material:	Polyester, UL 94V-0
Standard:	PBT
Contact Plating:	Tin, Gold or Selective Plated
Standard:	Gold Flash Overall

P.C.B Layout

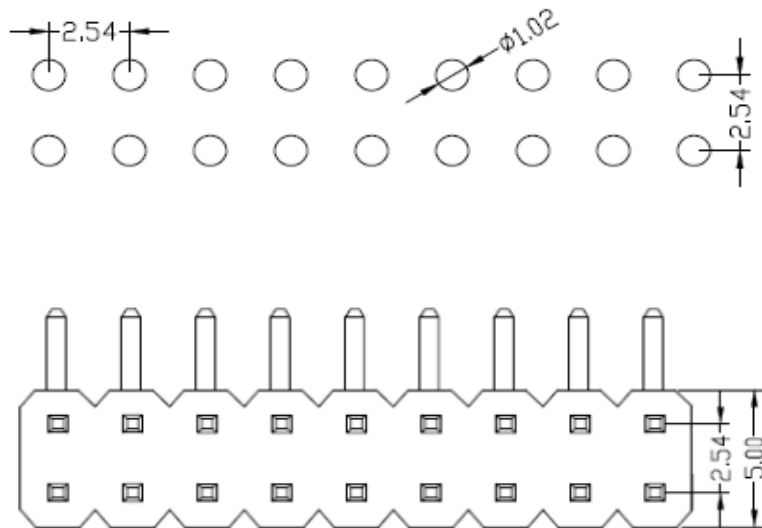

Drawing

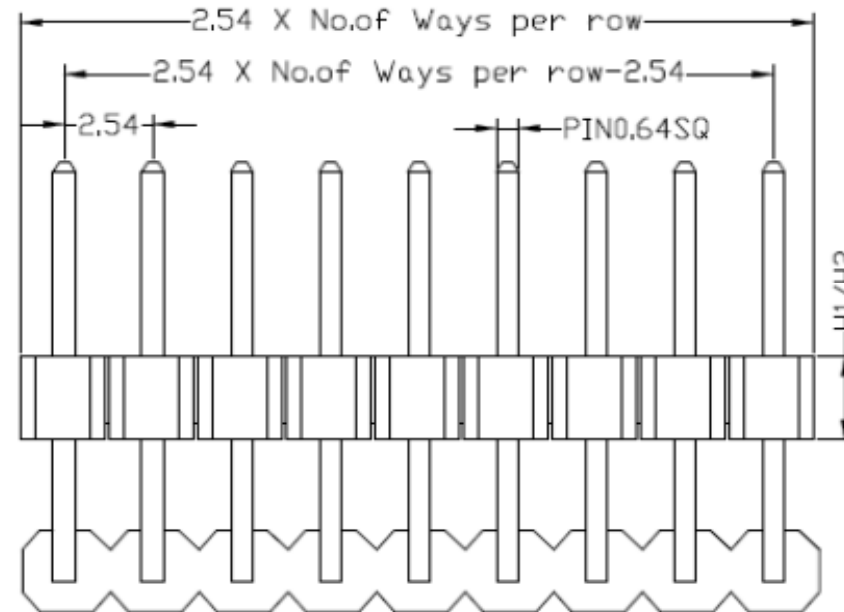

**Male Header Pitch
2,54mm**

Part No.: **T51A1064-**

Customer:

DRW:	Jason	CHKD	Wilson	MATL:	Wilson	TOLERANCE	Mason	DATE	19.07.2021
APPD:	Schumi			FINISH	Jamy		Sheet No.		1 from 4

EDCON-COMPONENTS



Pin Code length table free configuration

Order Code	Dimension (mm)		
	A	B	D
A01	6,00	3,00	1,20
A02	7,00	3,00	1,20
A03	8,00	3,00	1,20
A04	3,00	1,50	1,04
A05			
A06			
A07			
A08			
A09			
A10			
A11			
A12			
A13			
A14			
A15			
A16			
A17			
A18			
A19			
A20			
A21			
A22			

Order Code	Dimension (mm)		
	A	B	
A23			
A24			
A25			
A26			
A27			
A28			
A29			
A30			
A31			
A32			
A33			
A34			
A35			
A36			
A37			
A38			
A39			
A40			
A41			
A42			
A43			
A44			

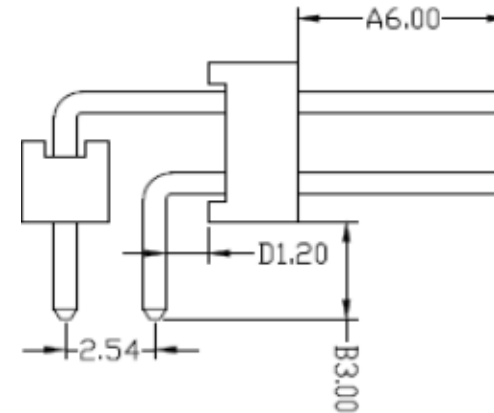

**Male Header Pitch
2,54mm**

						X=	X.X=	X.XX=	X.XXX=	Part No.:
DRW:	Jason	CHKD	Wilson	MATL:	Wilson	±0,35	±0,25	±0,20	±0,15	T51A1064-
APPD:	Schumi			FINISH	Jamy	TOLERANCE	Mason	DATE	19.07.2021	Customer:
							Sheet No.	2 from 4		

EDCON-COMPONENTS

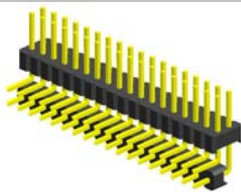

Ordering Informations

Serie	No. of Pos.	Construction	Contact Plating	Material	Special function	Pin Length Code	ROHS	Packing		
T51A1064-	XX	RT	G0	PB	1	A01	R	BU		

04 ~ 80Pos.	RS= Right angle THT	G0= Gold Flash (Standard)	PB= P.B.T	1= Plastic Thickness 2,00mm	look Table No. 1	N= NO ROHS conform	BU= Bulk (Standard)
		T0= Tin plated	NY= Nylon-6T				2= Plastic Thickness 2,54mm
		T0= Tin plated	PA= PA-46	TC= Tube w. pic and Place Cap			
		GA= 3µ Gold Plating	LC= LCP	TY= Tray packing w/o Cap			
		GB= 5µ Gold Plating		TR= Tape/Reel w. pic and Place Cap			
		GC= 10µ Gold Plating					
		GD= 15µ Gold Plating					
		GE= 20µ Gold Plating					
		GF= 30µ Gold Plating					
		S0= Selectiv Plating Gold Flash / Tin					

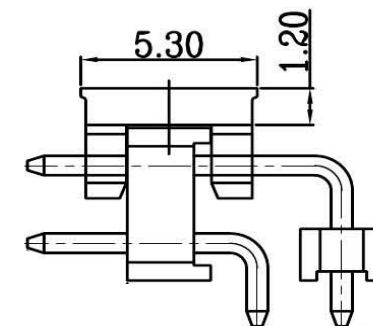
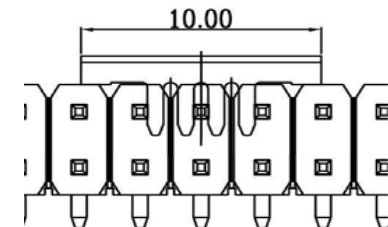

Male Header Pitch 2,54mm
Part No.: T51A1064-
Customer:

DRW:	Jason	CHKD	Wilson	MATL:	Wilson	TOLERANCE	Mason	DATE	19.07.2021
APPD:	Schumi			FINISH	Jamy		Sheet No.		3 from 4

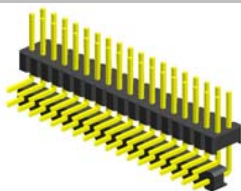

Soldering Profile for Lead Soldering (P.B.T.)

Soldering Profile for Lead Free Soldering (Nylon 6T)

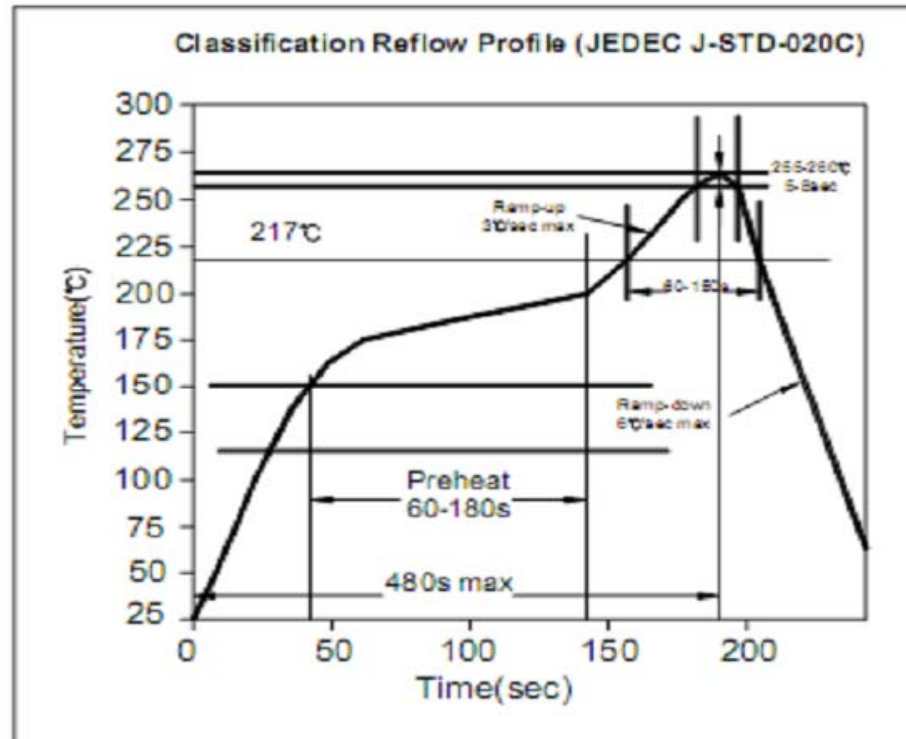
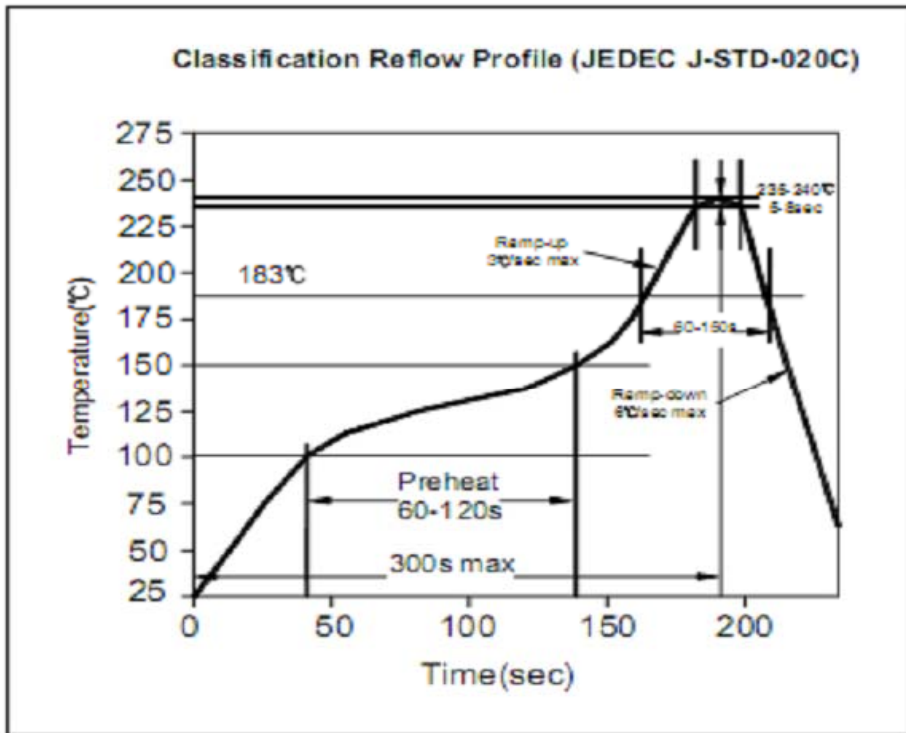

Male Header Pitch 2,54mm	
Part No.:	T51A1064-
Customer:	

DRW:	Jason	CHKD	Wilson	MATL:	Wilson	TOLERANCE	Mason	DATE	19.07.2021
APPD:	Schumi			FINISH	Jamy		Sheet No.		4 from 4