

EDCON-COMPONENTS



Features

Frequency Range 3,000MHz ~ 100MHz
 THT Soldering
 High shock Tolerance
 Good stability and high reliability
 Reliable frequency stability
 Copes with high density mounting and is the optimum for mass produc.

Applications

For a clock source in digital equipments
 Microprozessor systems
 Consumer Electronics
 Instrumentation
 Automotive electronics

Specifications

Frequency Range:		1,8432Mhz ~ 150MHz	
Load capacitance		16pf,,20pf,30pf or specify	
Drive Level		100µW typ.	
Frequency Tolerance		./-30ppm at 25°C Typical / or Specify	at 25°C Need to specify
Series Resistance:		Look table	at 25°C Depend on frequency
Turnover Temperature:		25 +/-5°C	
Temperature Coeffizient:		(-0,034 +/-0,006) ppm/°C	
Operating Temperature		look order Code	
Storage Temperature Range		. -40°C ~ +85°C	
Parallel Capacitance:		7,0pf Typ.	
Aging (First Year)		./- 3ppm Max.	at 25°C +/-3°C
Quality Factor		50000 Typ.	
Insulation resistance		500MΩ Min.	DC100V +/-15V (Pin to Pin, Pin to Case)

Temperature Range	Frequency Stability					
	./-10ppm	./-15ppm	./-20ppm	./-25ppm	./-30ppm	./-50ppm
.-10°C ~ +60°C	√	√	√	√	√	√
.-20°C ~ +70°C			√	√	√	√
.-40°C ~ +85°C						√

**Quarz Crystal Case HC49
 Height 4,5mm max.**

Part No.: **O11013**

DRW:	Jose	CHKD	John	MATL:	Victoria	TOLERANCE	Mu Tao	DATE	16.02.2016	Customer:
APPD:	Victor			FINISH	Oliver		Sheet No.		1 from 4	

EDCON-COMPONENTS



Technical Dimensions Dimensions (mm)

Frequency Stability us Operating Temperature Range

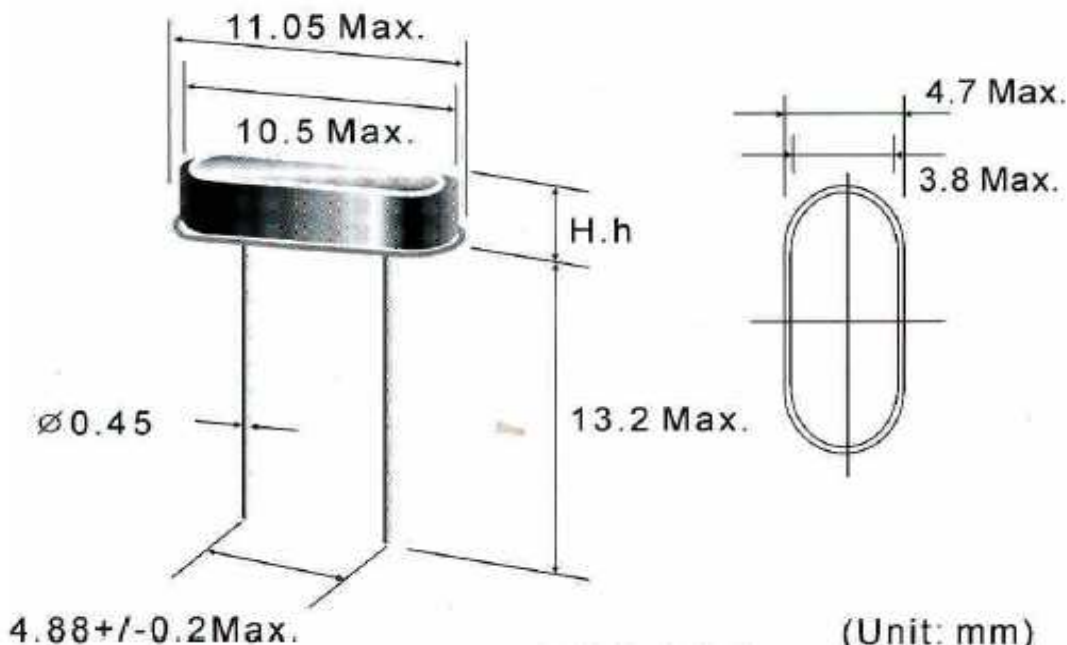

Frequency Range	E.S.R (Ω)	Mode
3,000Mhz ~ 5,999Mhz	150 max.	Fundamental / AT
6,000Mhz ~ 7,999Mhz	60 max.	Fundamental / AT
8,000Mhz ~ 15,999Mhz	50 max.	Fundamental / AT
16,000Mhz ~ 30,000Mhz	30 max.	Fundamental / AT
24,000Mhz ~ 40,320Mhz	30 max.	Fundamental / AT
24,000Mhz ~ 29,999Mhz	100 max.	Third Overtone
30,000Mhz ~ 49,999Mhz	80 max.	Third Overtone
50,000Mhz ~ 100,00Mhz	60 max.	Third Overtone

**Quarz Crystal Case HC49
Height 4,5mm max.**

Part No.: **O11013**

DRW:	Jose	CHKD	John	MATL:	Victoria	TOLERANCE	Mu Tao	DATE	16.02.2016
APPD:	Victor			FINISH	Oliver		Sheet No.	2 from 4	

Customer:

EDCON-COMPONENTS



Ordering Informations

Serie	Frequency Range	Frequency Tolerance	Load Capacity	Temperature Range	Frequency Stability	Mode	ROHS	Packing
O11013	3M0000000	B	D	B	A	1	R	BU
10 Letters (empty fill w. 0)	B= +/-30ppm	D= 16pf	B= -10°C ~ +60°C	A= +/-50ppm	1= Fundamental	R= ROHS Conform	BU= Bulk Ware	
	C= +/-20ppm	G= 20pf	D= -20°C ~ +70°C	B= +/-30ppm	3= 3th Overtone			N= NON ROHS Conform
	D= +/-10ppm	H= 30pf	F= -40°C ~ +85°C	C= +/-25ppm	5= 5th Overtone			
		C= 12pf		D= +/-20ppm				
		J= 32pf		E= +/-15ppm				
			F= +/-10ppm					

**Quarz Crystal Case HC49
Height 4,5mm max.**

Part No.: **O11013**

DRW:	Jose	CHKD	John	MATL:	Victoria	TOLERANCE	Mu Tao	DATE	16.02.2016
APPD:	Victor			FINISH	Oliver		Sheet No.		3 from 4

Customer:
email: info@edcon-components.com



Soldering Profile

Classification Reflow Profile (JEDEC J-STD-020C)

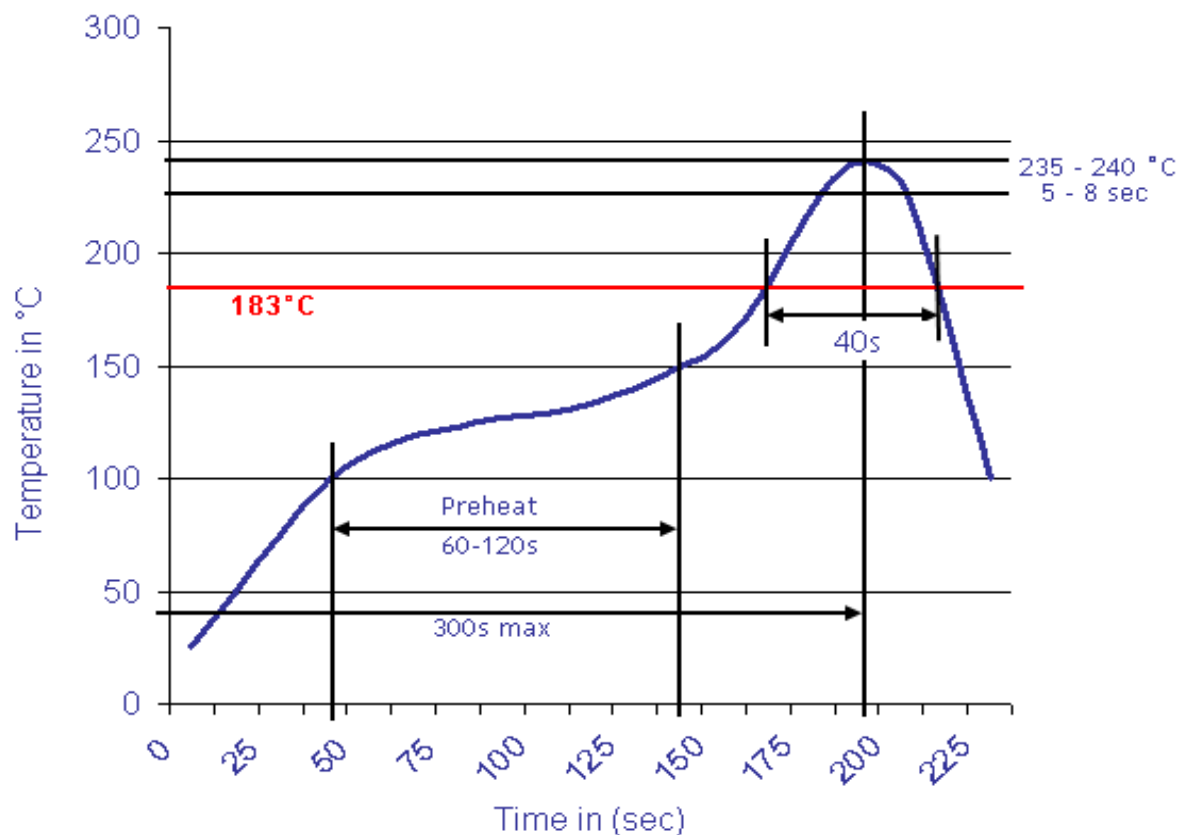

**Quarz Crystal Case HC49
Height 4,5mm max.**

Part No.: **O11013**

DRW:	Jose	CHKD	John	MATL:	Victoria	TOLERANCE	Mu Tao	DATE	16.02.2016
APPD:	Victor			FINISH	Oliver		Sheet No.	4 from 4	Customer: