

EDCON-COMPONENTS

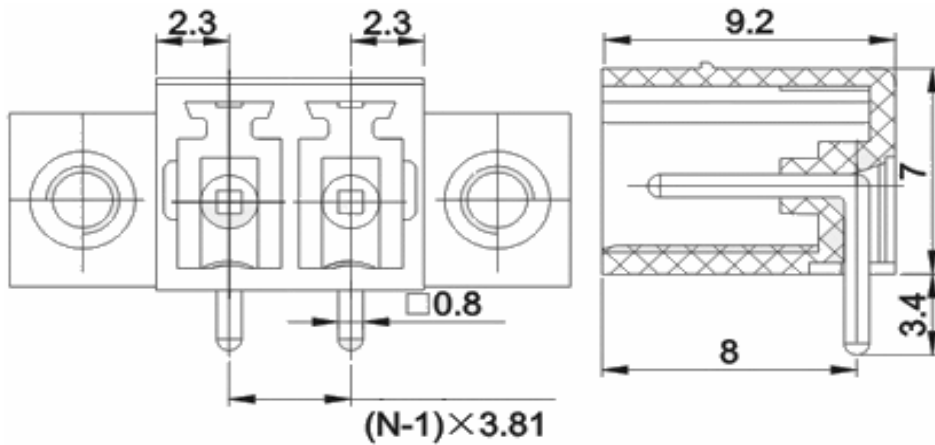

Drawing



P.C.B. Layout

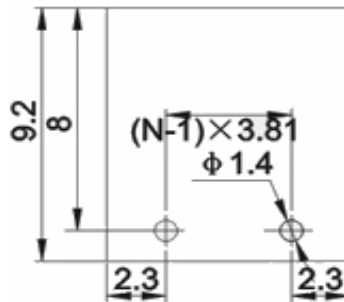

Specification

Electrical

Rated voltage	300V
Rated current	8A
Contact resistance	20mΩ
Insulation resistance	5000MΩ / 1000V
Withstand voltage	AC1500V/1min

Mechanical

Ambient temperature	-40°C ~ +130°C
Soldering temperature	250°C/5sec

Dimensions

Pitch	3.81mm
Poles	2P - 24P

Material

Housing	PA66 (UL94V-0)
Wire guard	Brass, Tin plated



Pluggable Terminal Block /
Pitch 3.81mm

Part No.: A14H117

Customer:

DRW:	Justin	CHKD	Frank	MATL:	Jordan	TOLERANCE	Lord	Date	10.02.2009
APPD:	Pete			FINISH	Mike		Sheet No.	1 from 3	

www.edcon-components.com

email: info@edcon-components.com



Ordering Informations

Serie	-	No. of Pole	Body-Color	-	Customer Request
A14H117	-	XX	XX	-	X
		XX = total	WH - white		
		02	GN - green		
		...	GR - gray		
		24	TP - transparent		
			OR - orange		
			BK - black		
			BL - blue		
			RD - red		
			YW - yellow		
			PG - Phoenix Green		



Pluggable Terminal Block / Pitch 3.81 mm	
Part No.:	A14H117
Customer:	

DRW:	Justin	CHKD	Frank	MATL:	Jordan	TOLERANCE	Lord	Date	10.02.2009
APPD:	Pete			FINISH	Mike			Sheet No.	2 from 3



Soldering - Profil

Classification Reflow Profile (JEDEC J-STD-020C)

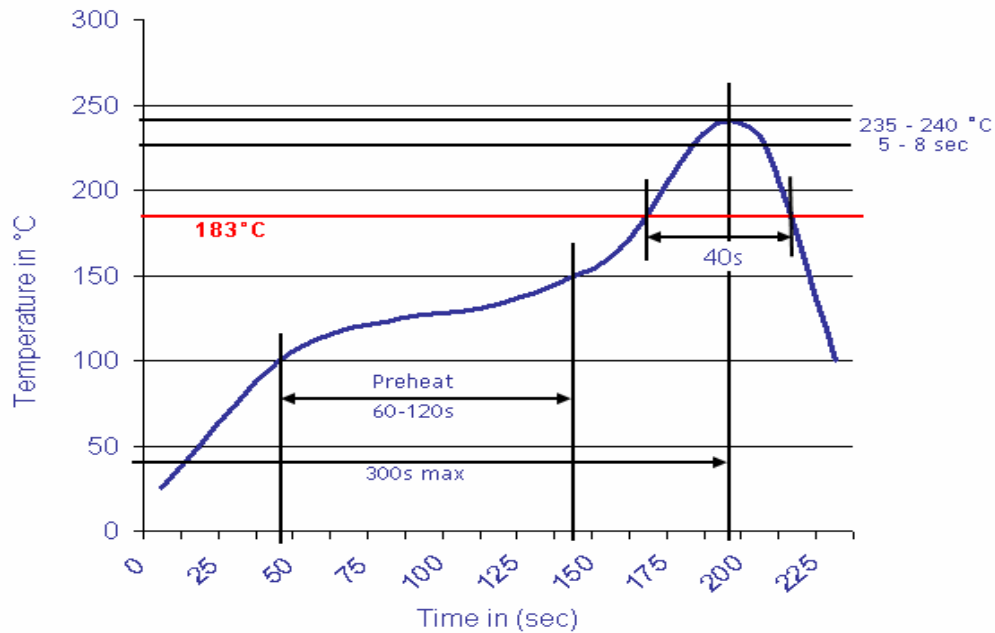

Pluggable Terminal Block / Pitch 3.81 mm	
Part No.:	A14H117

DRW:	Justin	CHKD	Frank	MATL:	Jordan	TOLERANCE	Lord	Date	10.02.2009
APPD:	Pete			FINISH	Mike			Sheet No.	3 from 3

Customer:	
-----------	--