

# Data Sheet

## Pluggable Terminal Block (Plug) Inverted

**Pitch: 7,62 mm**

**Serie: A14R035**

### Customer Information for special Item

**EDCON Customer : 0**

**Customer Version No. : 0**

# EDCON-COMPONENTS



## Technical Discription

## Drawing (Dimension in mm)

|                       | <b>Approvals</b>              |      |
|-----------------------|-------------------------------|------|
|                       | UR/US                         | IEC  |
| <b>Electrical</b>     |                               |      |
| Rated Voltage         | 300V                          | 400V |
| Rated Current         | 20A                           | 20A  |
| Wire Range            | 2,5mm <sup>2</sup>            |      |
| Solid Wire            | 12 ~ 28                       |      |
| Standed Wire          | 12 ~ 24                       |      |
| Withstanding Voltage  | 1,6KV                         |      |
| Insulation Resistance | 5000MΩ / 1000V                |      |
| <b>Mechanical</b>     |                               |      |
| Operating Temperature | -40°C ~ +115°C                |      |
| Wire Strip Length     | 7-8mm                         |      |
| Screw Torque          | 4 LB-In                       |      |
| Screw Size            | M3                            |      |
| <b>Dimensions</b>     |                               |      |
| Pitch (mm)            | 7,62                          |      |
| Poles                 | 2 ~ 16 Pos.                   |      |
| <b>Materials</b>      |                               |      |
| Terminal Housing      | Thermoplastic, UL94V-0        |      |
| Clamp                 | Brass Ni-plated               |      |
| Female Contact        | Copper tin-plated             |      |
| Screw                 | Steel Ni-plated / Zinc plated |      |
| Male Contact Pin      | Brass tin-plated              |      |

| No. of Pos. | A      | B      |  |  | Tol. B |
|-------------|--------|--------|--|--|--------|
| 02          | 15,14  | 7,62   |  |  | ± 0,15 |
| 03          | 22,76  | 15,24  |  |  | ± 0,15 |
| 04          | 30,38  | 22,86  |  |  | ± 0,15 |
| 05          | 38,00  | 30,48  |  |  | ± 0,25 |
| 06          | 45,62  | 38,10  |  |  | ± 0,25 |
| 07          | 53,24  | 45,72  |  |  | ± 0,25 |
| 08          | 60,86  | 53,34  |  |  | ± 0,25 |
| 09          | 68,48  | 60,96  |  |  | ± 0,30 |
| 10          | 76,10  | 68,58  |  |  | ± 0,30 |
| 11          | 83,72  | 76,20  |  |  | ± 0,30 |
| 12          | 91,34  | 83,82  |  |  | ± 0,30 |
| 13          | 98,96  | 91,44  |  |  | ± 0,40 |
| 14          | 106,58 | 99,06  |  |  | ± 0,40 |
| 15          | 114,20 | 106,68 |  |  | ± 0,40 |
| 16          | 121,82 | 114,30 |  |  | ± 0,40 |
|             |        |        |  |  |        |
|             |        |        |  |  |        |
|             |        |        |  |  |        |
|             |        |        |  |  |        |
|             |        |        |  |  |        |
|             |        |        |  |  |        |
|             |        |        |  |  |        |
|             |        |        |  |  |        |
|             |        |        |  |  |        |
|             |        |        |  |  |        |
|             |        |        |  |  |        |
|             |        |        |  |  |        |
|             |        |        |  |  |        |
|             |        |        |  |  |        |
|             |        |        |  |  |        |

|                                                     |                |
|-----------------------------------------------------|----------------|
| <b>Pluggable Terminal Block<br/>(Plug) Inverted</b> |                |
| Part No.:                                           | <b>A14R035</b> |
| Customer:                                           |                |

|       |        |      |        |        |        |           |           |      |            |
|-------|--------|------|--------|--------|--------|-----------|-----------|------|------------|
| DRW:  | Jason  | CHKD | Wilson | MATL:  | Wilson | TOLERANCE | Mason     | DATE | 27.03.2022 |
| APPD: | Schumi |      |        | FINISH | Jamy   |           | Sheet No. |      | 1 from 3   |

# EDCON-COMPONENTS



Drawing (Dimension in mm)

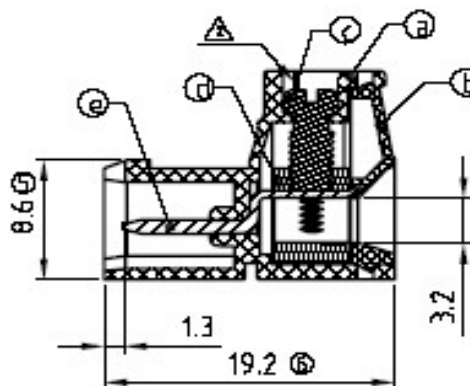
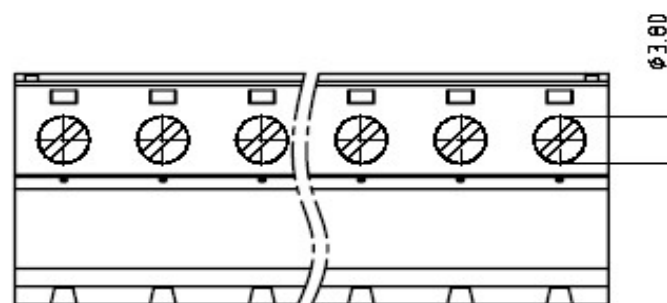
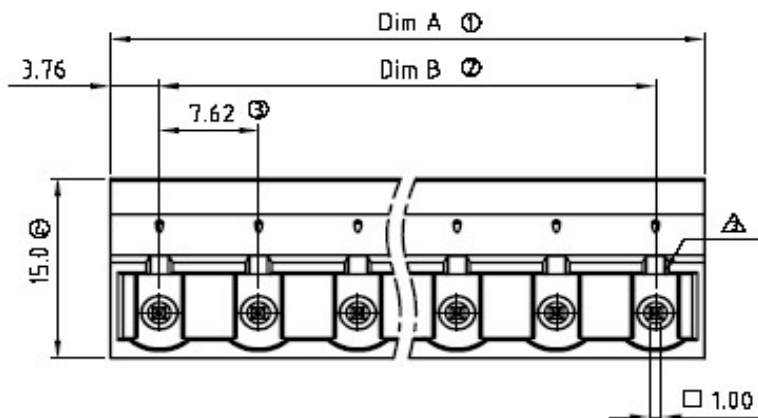

**Pluggable Terminal Block  
(Plug) Inverted**

Part No.: **A14R035**

|       |        |      |        |        |        |           |           |          |            |           |
|-------|--------|------|--------|--------|--------|-----------|-----------|----------|------------|-----------|
| DRW:  | Jason  | CHKD | Wilson | MATL:  | Wilson | TOLERANCE | Mason     | DATE     | 27.03.2022 | Customer: |
| APPD: | Schumi |      |        | FINISH | Jamy   |           | Sheet No. | 2 from 3 |            |           |

[www.edcon-components.com](http://www.edcon-components.com)

email: [info@edcon-components.com](mailto:info@edcon-components.com)

Copyright by S.Tiede



# EDCON-COMPONENTS



## Ordering Informations

| Serie | No. of Pos. | Body Color | Screw Type | Approval Code | ROHS | Packing | EDCON Cust. No. | Customer Version |  |  |
|-------|-------------|------------|------------|---------------|------|---------|-----------------|------------------|--|--|
|-------|-------------|------------|------------|---------------|------|---------|-----------------|------------------|--|--|

|                |           |           |          |          |          |          |  |  |  |  |
|----------------|-----------|-----------|----------|----------|----------|----------|--|--|--|--|
| <b>A14R035</b> | <b>02</b> | <b>PG</b> | <b>A</b> | <b>N</b> | <b>R</b> | <b>B</b> |  |  |  |  |
|----------------|-----------|-----------|----------|----------|----------|----------|--|--|--|--|

|               |                                                   |                                                                                                                                                                                             |                                                                                                                                                                                                                                                           |                                                                                                                                                                                   |                                                        |                                                       |                                 |                                            |  |  |
|---------------|---------------------------------------------------|---------------------------------------------------------------------------------------------------------------------------------------------------------------------------------------------|-----------------------------------------------------------------------------------------------------------------------------------------------------------------------------------------------------------------------------------------------------------|-----------------------------------------------------------------------------------------------------------------------------------------------------------------------------------|--------------------------------------------------------|-------------------------------------------------------|---------------------------------|--------------------------------------------|--|--|
| Pitch<br>7,62 | <b>02</b> = Number of Pos.<br>Standard 2 ~ 24Pos. | <b>PG</b> = Phoenix Green (Standard)<br><b>WH</b> = White<br><b>GN</b> = Green<br><b>GY</b> = Gray<br><b>LG</b> = Light Gray<br><b>OR</b> = Orange<br><b>BL</b> = Blue<br><b>BK</b> = Black | <b>A</b> = Slotted Screw Type (Standard)<br><br><b>B</b> = Cross Slotted Screw Type<br> | <b>0</b> = NON Approval<br><b>N</b> = UL /UR Approval<br><b>B</b> = VDE Approval Please consult EDCON for available<br><b>C</b> = TÜV Approval Please consult EDCON for available | <b>R</b> = ROHS Conform<br><b>N</b> = NON ROHS Conform | <b>B</b> = Bulk-Ware<br><b>I</b> = Individual Package | <b>xxxxxx</b> = Customer Number | <b>xxx</b> = Customer Version ??(Printing) |  |  |
|---------------|---------------------------------------------------|---------------------------------------------------------------------------------------------------------------------------------------------------------------------------------------------|-----------------------------------------------------------------------------------------------------------------------------------------------------------------------------------------------------------------------------------------------------------|-----------------------------------------------------------------------------------------------------------------------------------------------------------------------------------|--------------------------------------------------------|-------------------------------------------------------|---------------------------------|--------------------------------------------|--|--|

**Pluggable Terminal Block (Plug) Inverted**

Part No.: **A14R035**

|       |        |      |        |        |        |           |           |      |            |
|-------|--------|------|--------|--------|--------|-----------|-----------|------|------------|
| DRW:  | Jason  | CHKD | Wilson | MATL:  | Wilson | TOLERANCE | Mason     | DATE | 27.03.2022 |
| APPD: | Schumi |      |        | FINISH | Jamy   |           | Sheet No. |      | 3 from 3   |

Customer: