

EDCON-COMPONENTS

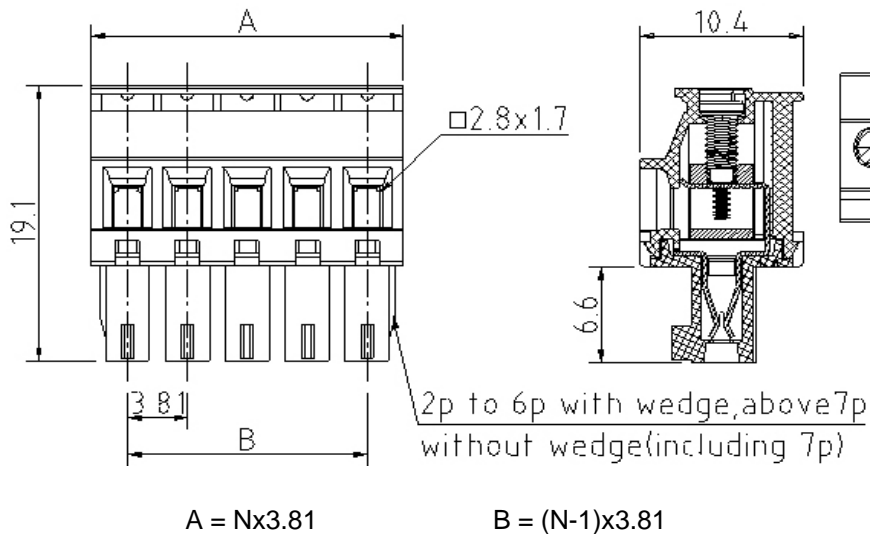

Drawing



P.C.B. Layout

Specification

APPROVAL



Electrical

Standard
 Rated voltage
 Rated current
 Withstanding voltage
 Wire range
 Screw, Torque

| | |
|--------------------------------|-------|
| cULus | VDE |
| 300V | 300V |
| 8A | 10A |
| 1.6KV | 2.5KV |
| 28-12 AWG / 1.5mm ² | |
| M2, 0.2Nm (1.7Lb-In.) | |

Mechanical

Ambient temperature
 Strip length

-40°C ~ +115°C
 6 ~ 7mm

Dimensions

Pitch
 Poles

3.81mm
 2P - 2P

Material

Housing
 Wire guard
 Terminal screw
 Metal housing

Thermoplastic (UL94V-0)
 PbZn (CuSn)
 Steel Zinc
 Brass (CuZn)



Certification



Pluggable Terminal Block /
 Pitch 3.81mm

Part No.: A14H090

Customer:

| | | | | | | | | | |
|-------|--------|------|-------|--------|--------|-----------|------|-----------|------------|
| DRW: | Justin | CHKD | Frank | MATL: | Jordan | TOLERANCE | Lord | Date | 10.02.2009 |
| APPD: | Pete | | | FINISH | Mike | | | Sheet No. | 1 from 3 |

www.edcon-components.com

email: info@edcon-components.com

EDCON-COMPONENTS



Ordering Informations

| Serie | - | No. of Pole | Body-Color | - | Customer Request |
|----------------|---|-------------|---------------------------|---|------------------|
| A14H090 | - | XX | XX | - | X |
| | | XX = total | WH - white | | |
| | | 02 | GN - green | | |
| | | ... | GR - gray | | |
| | | 24 | TP - transparent | | |
| | | | OR - orange | | |
| | | | BK - black | | |
| | | | BL - blue | | |
| | | | RD - red | | |
| | | | YW - yellow | | |
| | | | PG - Phoenix Green | | |



Certification



| | |
|--|---------|
| Pluggable Terminal Block / Pitch 3.81mm | |
| Part No.: | A14H090 |
| Customer: | |

| | | | | | | | | | |
|-------|--------|------|-------|--------|--------|-----------|------|-----------|------------|
| DRW: | Justin | CHKD | Frank | MATL: | Jordan | TOLERANCE | Lord | Date | 10.02.2009 |
| APPD: | Pete | | | FINISH | Mike | | | Sheet No. | 2 from 3 |

www.edcon-components.com

email: info@edcon-components.com

Copyright by EDCON-COMPONENTS

EDCON-COMPONENTS



Soldering - Profil

Classification Reflow Profile (JEDEC J-STD-020C)

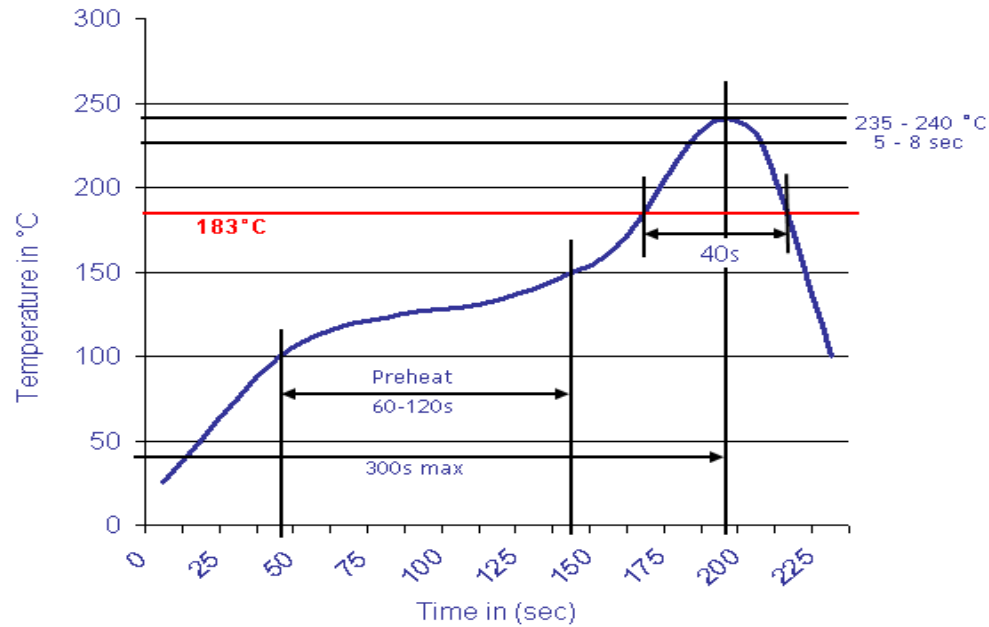

| | |
|--|---------|
| Pluggable Terminal Block / Pitch 3.81mm | |
| Part No.: | A14H090 |
| Customer: | |

| | | | | | | | | | |
|-------|--------|------|-------|--------|--------|-----------|------|-----------|------------|
| DRW: | Justin | CHKD | Frank | MATL: | Jordan | TOLERANCE | Lord | Date | 10.02.2009 |
| APPD: | Pete | | | FINISH | Mike | | | Sheet No. | 3 from 3 |