

# EDCON-COMPONENTS

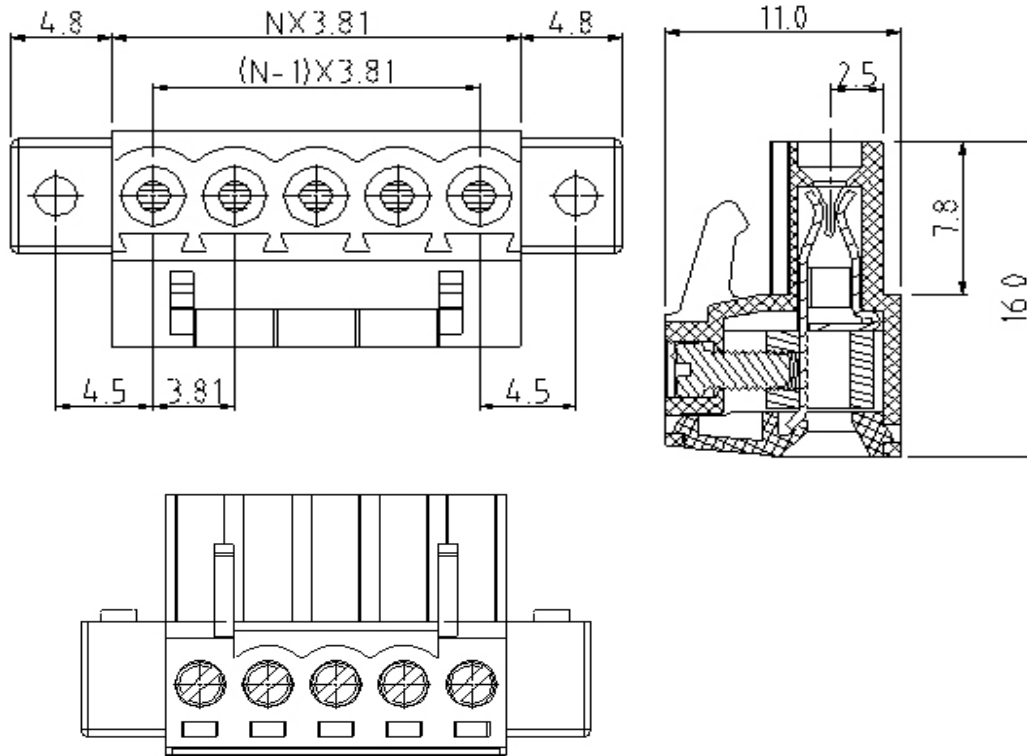

## Drawing



## Specification

### APPROVAL



#### Electrical

Standard  
Rated voltage  
Rated current  
Wire range  
Withstanding voltage

cULus  
300V  
8A  
28-16 AWG  
1.6KV

#### Mechanical

Ambient temperature  
Strip length  
Screw, Torque

-30°C ~ +105°C  
6 ~ 7mm  
M2, 0.2Nm (1.7Lb-In.)

#### Dimensions

Pitch  
Poles

3.81mm  
2P - 24P

#### Material

Housing  
Pin header  
Wire guard  
Terminal screw  
Metal housing

Thermoplastic (UL94V-0)  
Brass, Tin plated  
PhBz (CuSn)  
Steel Zinc  
Brass (CuZn)



Certification



Pluggable Terminal Block /  
Pitch 3.81mm

Part No.: A14H078

Customer:

DRW:	Justin	CHKD	Frank	MATL:	Jordan	TOLERANCE	Lord	Date	10.02.2009
APPD:	Pete			FINISH	Mike			Sheet No.	1 from 3

[www.edcon-components.com](http://www.edcon-components.com)

email: [info@edcon-components.com](mailto:info@edcon-components.com)

# EDCON-COMPONENTS



## Ordering Informations

Serie	-	No. of Pole	Body-Color	-	Customer Request
<b>A14H078</b>	-	<b>XX</b>	<b>XX</b>	-	<b>X</b>
		XX = total	<b>WH</b> - white		
		02	<b>GN</b> - green		
		...	<b>GR</b> - gray		
		24	<b>TP</b> - transparent		
			<b>OR</b> - orange		
			<b>BK</b> - black		
			<b>BL</b> - blue		
			<b>RD</b> - red		
			<b>YW</b> - yellow		
			<b>PG</b> - Phoenix Green		



Certification



Pluggable Terminal Block / Pitch 3.81mm	
Part No.:	A14H078
Customer:	

DRW:	Justin	CHKD	Frank	MATL:	Jordan	TOLERANCE	Lord	Date	10.02.2009
APPD:	Pete			FINISH	Mike		Sheet No.		2 from 3

[www.edcon-components.com](http://www.edcon-components.com)

email: [info@edcon-components.com](mailto:info@edcon-components.com)



**Soldering - Profil**

Classification Reflow Profile (JEDEC J-STD-020C)

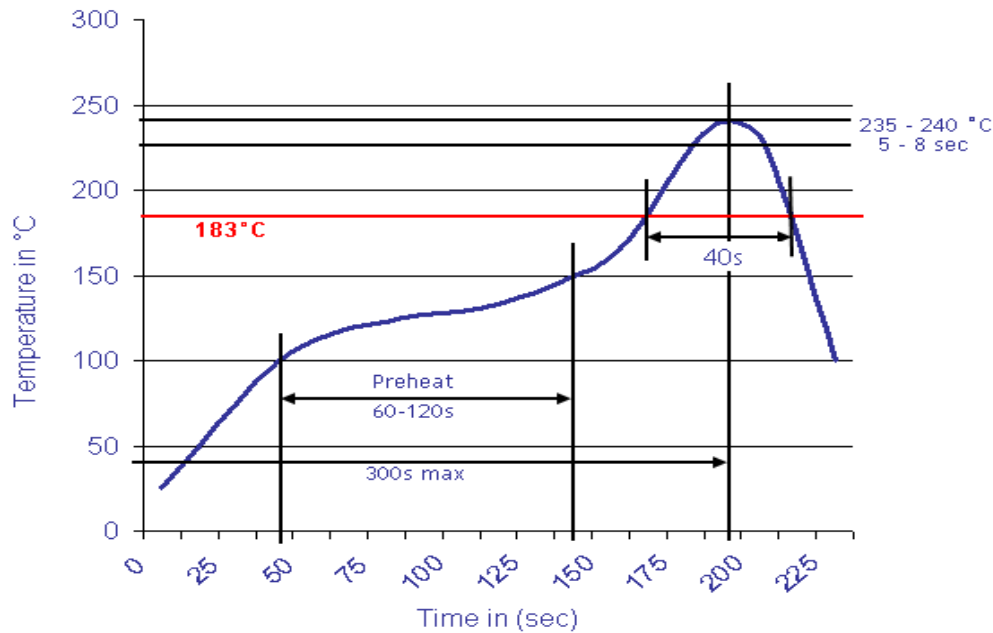

Pluggable Terminal Block /  
Pitch 3.81 mm

Part No.: A14H078

DRW:	Justin	CHKD	Frank	MATL:	Jordan	TOLERANCE	Lord	Date	10.02.2009
APPD:	Pete			FINISH	Mike			Sheet No.	3 from 3

Customer: