

EDCON-COMPONENTS

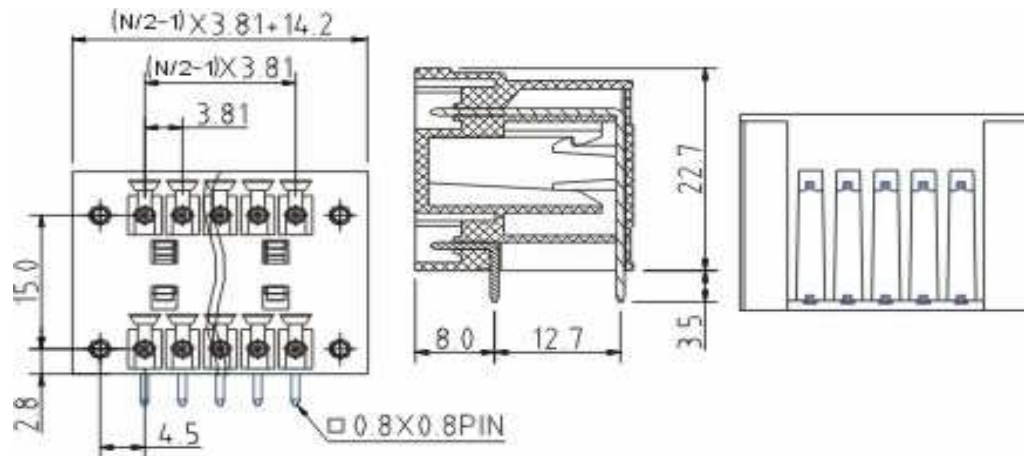

Drawing



P.C.B. Layout



Specification

APPROVAL



Electrical

Standard
Rated voltage
Rated current
Withstanding voltage

cULus
300V
10A
1.6KV

Mechanical

Ambient temperature
Soldering temperature

-40°C ~ +115°C
250°C ± 10°C/5 sec

Dimensions

Pitch
Poles

3.81mm
2x (2P - 24P)

Material

Housing
Pin header

Thermoplastic (UL94V-0)
Brass, Tin plated



Certification



Pluggable Terminal Block /
Pitch 3.81mm

Part No.: A14H069

Customer:

DRW:	Justin	CHKD	Frank	MATL:	Jordan	TOLERANCE	Lord	Date	10.02.2009
APPD:	Pete			FINISH	Mike			Sheet No.	1 from 3

www.edcon-components.com

email: info@edcon-components.com

EDCON-COMPONENTS



Ordering Informations

Serie	-	No. of Pole	Body-Color	-	Customer Request
-------	---	-------------	------------	---	------------------

A14H069	-	XX	XX	-	X
		XX = total	WH - white		
		2x 02	GN - green		
		...	GR - gray		
		2x 24	TP - transparent		
			OR - orange		
			BK - black		
			BL - blue		
			RD - red		
			YW - yellow		
			PG - Phoenix Green		



Certification



Pluggable Terminal Block / Pitch 3.81mm	
Part No.:	A14H069
Customer:	

DRW:	Justin	CHKD	Frank	MATL:	Jordan	TOLERANCE	Lord	Date	10.02.2009
APPD:	Pete			FINISH	Mike			Sheet No.	2 from 3

www.edcon-components.com

email: info@edcon-components.com



Soldering - Profil

Classification Reflow Profile (JEDEC J-STD-020C)

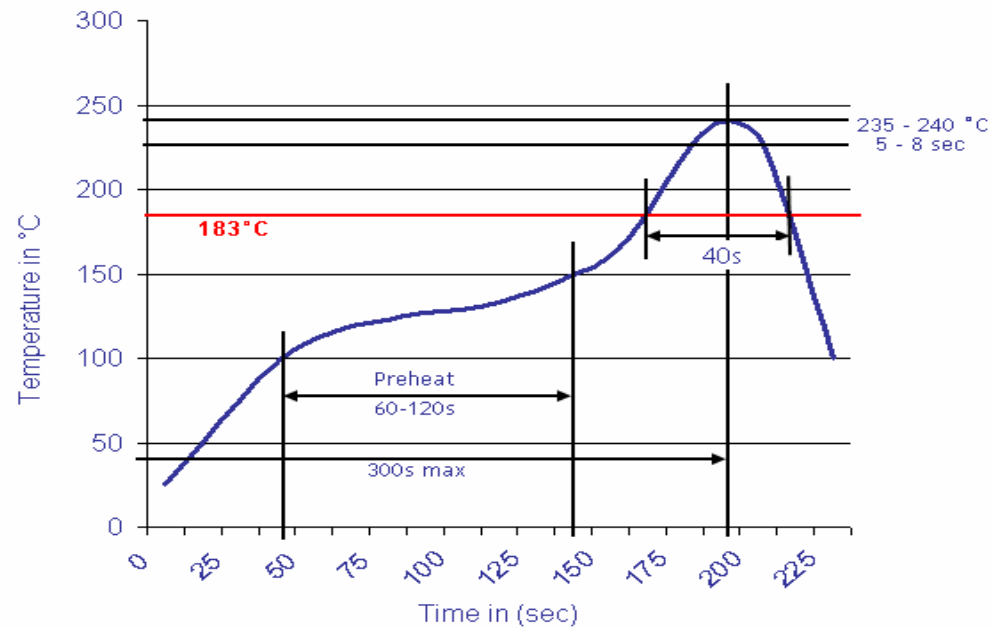

Pluggable Terminal Block /
Pitch 3.81mm

Part No.: A14H069

Customer:

DRW:	Justin	CHKD	Frank	MATL:	Jordan	TOLERANCE	Lord	Date	10.02.2009
APPD:	Pete			FINISH	Mike			Sheet No.	3 from 3