

Data Sheet

Plug Screw-Type w/o mounting Flange

Pitch: 3,81 mm

Serie: A14H002

Customer Information for special Item

EDCON Customer : 0

Customer Version No. : 0

EDCON-COMPONENTS



Technical Description

UL/CUL Techn.Data			
Use Group	B	C	D
Rated Voltage: (V)	300	-	300
Rated Current: (A)	8	-	8
Wire Range Solid / Stranded	26~16AWG		
Withstanding Voltage:	1600V/1Min		
IEC Techn. Data VDE			
Overvoltage Category	III	III	II
Contamination Class	3	2	2
Rated Voltage: (V)	160	160	250
Rated Current: (A)	7	7	7
Impulse withstand Voltage (KV)	2,5	2,5	2,5
Conductor Cross Section (mm ²)	0,5~1,5mm ²		

Material	
Insulator Material:	PA66
Imflammability:	UL94V-0
Contact Material	Copper Alloy
Surface Coating:	NI- Plated

Other Informations	
Pitch:(mm)	3,81
Poles: (P)	2 ~ 24
Stripping Length: (mm)	6,0~7,0
Srew Torque max.(Nm)	0.2Nm (1.77Lb-In.)
Operating Temp.: (°C)	-.40°C to +105°C
Pin Dimension: (mm)	
PCB Hole Diameter (mm)	
Screw-Size	M2

Drawing (Dimension in mm)

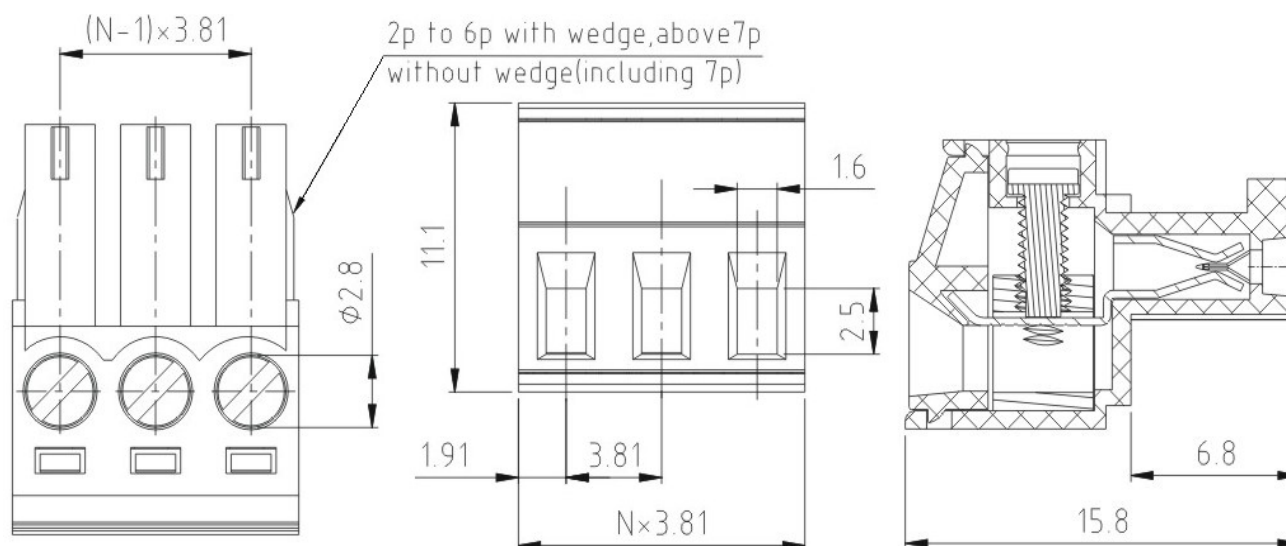

DRW:	Jason	CHKD	Wilson	MATL:	Wilson
APPD:	Schumi			FINISH	Jamy

Tolerances unless otherwise specified (mm)				
x	x.x	x.xx	x.xxx	Angle
±	±0,60	±0,30	±0,10	±3°
				16.06.2024
				1 from 2

Plug Screw-Type w/o mounting Flange	
Part No.:	A14H002
Customer:	

www.edcon-components.com

email: info@edcon-components.com

EDCON-COMPONENTS





Ordering Informations

Serie	No. of Pos.	Body Color	Approval Code	Screw Type	ROHS	Packing	EDCON Cust. No.	Customer Version		
-------	-------------	------------	---------------	------------	------	---------	-----------------	------------------	--	--

A14H002	XX	PG	N	A	R	B				
----------------	-----------	-----------	----------	----------	----------	----------	--	--	--	--

Pitch 3,81										
---------------	--	--	--	--	--	--	--	--	--	--

Standard 2 ~ 24Pos.	PG= Phoenix Green (Standard)	1= NON Approval	A= Slotted Screw Type (Standard) 	R= ROHS Conform	B= Bulk-Ware	xxxxxx= Customer Number	xxx= Customer Version ??(Printing)
	WH= White	N= Approval for Body Material					
	GN= Green	A= UL /UR Approval Please consult EDCON for available	B= Cross Slotted Screw Type 				
	GY= Gray						
	LG= Light Gray						
	OR= Orange	B= VDE Approval Please consult EDCON for available	C= Screwless Type				
	BL= Blue						
	BK= Black						
		C= TÜV Approval Please consult EDCON for available					

Plug Screw-Type w/o mounting Flange	
Part No.:	A14H002
Customer:	

DRW:	Jason	CHKD	Wilson	MATL:	Wilson	TOLERANCE	Mason	DATE	16.06.2024
APPD:	Schumi			FINISH	Jamy		Sheet No.		2 from 2