

# EDCON-COMPONENTS

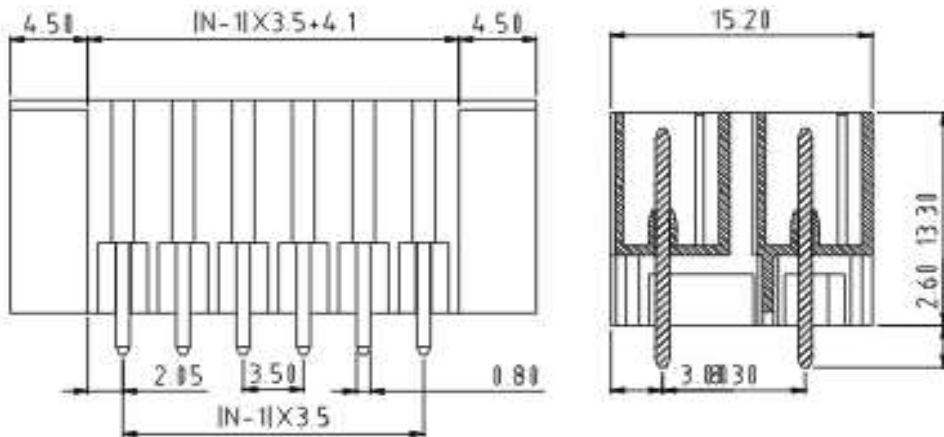

## Drawing



## P.C.B. Layout

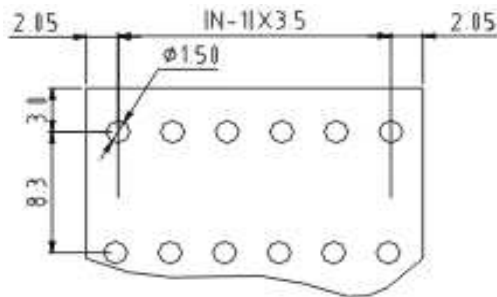

## Specification

### APPROVAL



#### Electrical

Standard  
Rated voltage  
Rated current  
Withstanding voltage

cULus  
160V  
5.5A  
1.32KV

#### Mechanical

Ambient temperature  
Soldering temperature

-30°C ~ +105°C  
250°C ± 10°C/5 sec

#### Dimensions

Pitch  
Poles

3.50mm  
2x (2P - 24P)

#### Material

Housing  
Pin header

Thermoplastic (UL94V-0)  
Brass, Tin plated



### Certification



Pluggable Terminal Block /  
Pitch 3.50mm

Part No.: A14G076

Customer:

DRW:	Justin	CHKD	Frank	MATL:	Jordan	TOLERANCE	Lord	Date	10.02.2009
APPD:	Pete			FINISH	Mike			Sheet No.	1 from 3

[www.edcon-components.com](http://www.edcon-components.com)

email: [info@edcon-components.com](mailto:info@edcon-components.com)

Copyright by EDCON-COMPONENTS

EDCON-COMPONENTS



### Ordering Informations

Serie	-	No. of Pole	Body-Color	-	Customer Request
<b>A14G076</b>	-	<b>XX</b>	<b>XX</b>	-	<b>X</b>
		XX = total	<b>WH</b> - white		
		2x 02	<b>GN</b> - green		
		...	<b>GR</b> - gray		
		2x 24	<b>TP</b> - transparent		
			<b>OR</b> - orange		
			<b>BK</b> - black		
			<b>BL</b> - blue		
			<b>RD</b> - red		
			<b>YW</b> - yellow		
			<b>PG</b> - Phoenix Green		



**Certification**



Pluggable Terminal Block /

Pitch 3.50mm

Part No.: A14G076

Customer:

DRW:	Justin	CHKD	Frank	MATL:	Jordan	TOLERANCE	Lord	Date	10.02.2009
APPD:	Pete			FINISH	Mike			Sheet No.	2 from 3

[www.edcon-components.com](http://www.edcon-components.com)

email: [info@edcon-components.com](mailto:info@edcon-components.com)

Copyright by EDCON-COMPONENTS



**Soldering - Profil**

Classification Reflow Profile (JEDEC J-STD-020C)

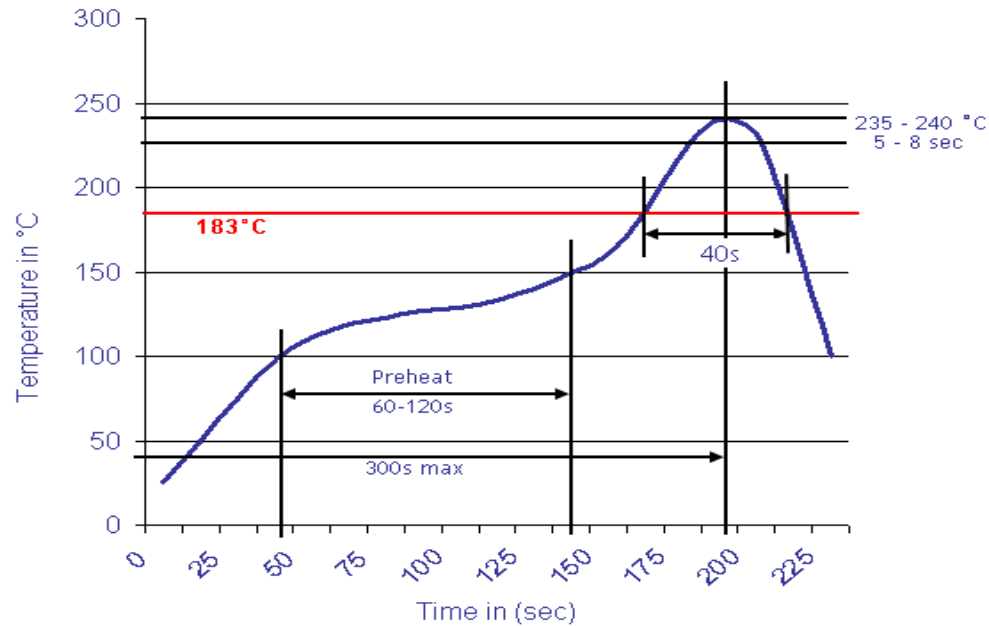

Pluggable Terminal Block / Pitch 3.50mm	
Part No.:	A14G076
Customer:	

DRW:	Justin	CHKD	Frank	MATL:	Jordan	TOLERANCE	Lord	Date	10.02.2009
APPD:	Pete			FINISH	Mike			Sheet No.	3 from 3