

EDCON-COMPONENTS

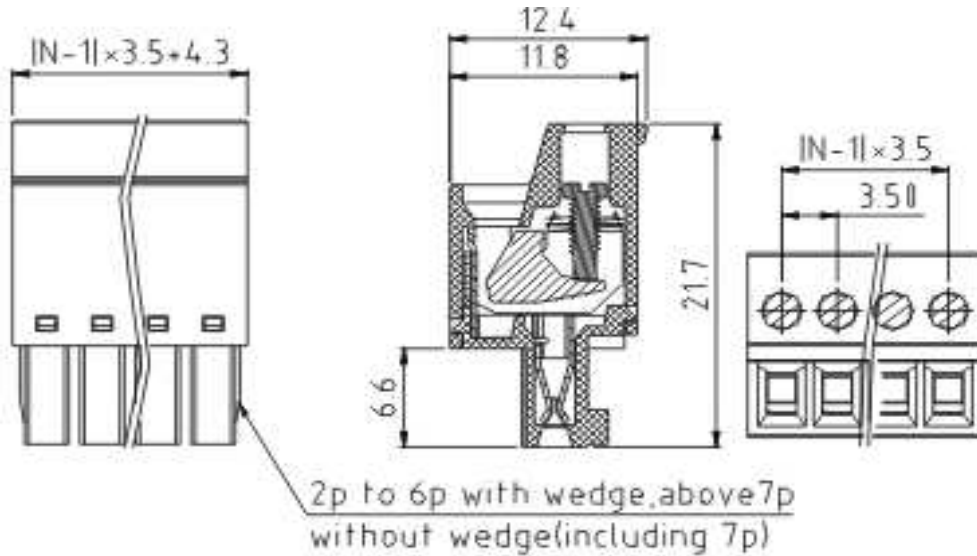

Drawing



P.C.B. Layout

Specification

APPLYING APPROVAL

(cULus)
pending

Electrical

Standard	cULus
Rated voltage	300V
Rated current	10A
Withstanding voltage	1.6KV
Wire range	28-16 AWG

Mechanical

Ambient temperature	-40°C ~ +115°C
Screw, Torque	M2, 0.2Nm (1.7Lb-In.)
Strip length	6 ~ 7mm

Dimensions

Pitch	3.50mm
Poles	2P - 24P

Material

Housing	Thermoplastic (UL94V-0)
Metal housing	Steel stamping
Wire guard	PhBz (CuSn)
Terminal screw	Steel Zinc



Certification



Pluggable Terminal Block /

Pitch 3.50mm

Part No.: A14G064

Customer:

DRW:	Justin	CHKD	Frank	MATL:	Jordan	TOLERANCE	Lord	Date	10.02.2009
APPD:	Pete			FINISH	Mike			Sheet No.	1 from 3

www.edcon-components.com

email: info@edcon-components.com

EDCON-COMPONENTS

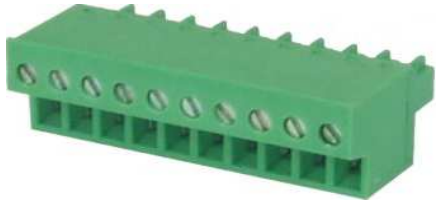

Ordering Informations

Serie	-	No. of Pole	Body-Color	-	Customer Request
A14G064	-	XX	XX	-	X
		XX = total	WH - white		
		02	GN - green		
		...	GR - gray		
		24	TP - transparent		
			OR - orange		
			BK - black		
			BL - blue		
			RD - red		
			YW - yellow		
			PG - Phoenix Green		



Certification



Pluggable Terminal Block /
Pitch 3.50mm

Part No.: A14G064

Customer:

DRW:	Justin	CHKD	Frank	MATL:	Jordan	TOLERANCE	Lord	Date	10.02.2009
APPD:	Pete			FINISH	Mike			Sheet No.	2 from 3

www.edcon-components.com

email: info@edcon-components.com



Soldering - Profil

Classification Reflow Profile (JEDEC J-STD-020C)

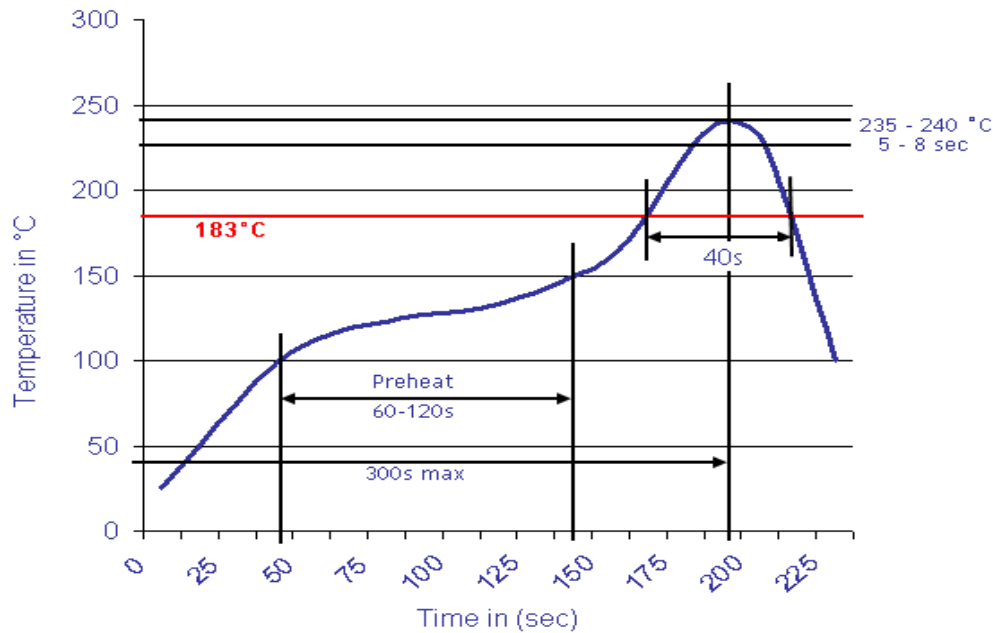

Pluggable Terminal Block / Pitch 3.50mm	
Part No.:	A14G064
Customer:	

DRW:	Justin	CHKD	Frank	MATL:	Jordan	TOLERANCE	Lord	Date	10.02.2009
APPD:	Pete			FINISH	Mike			Sheet No.	3 from 3