

EDCON-COMPONENTS

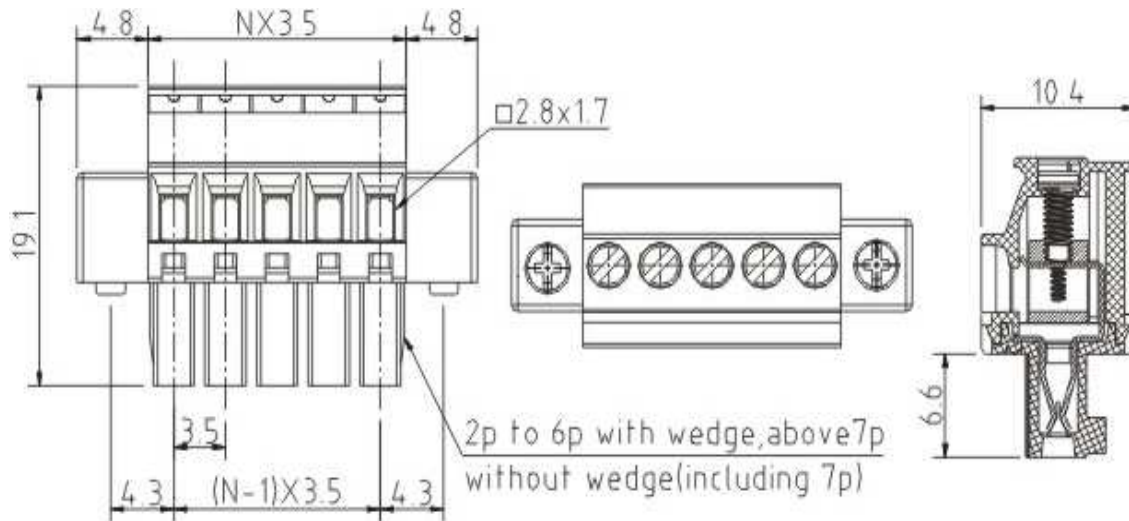

Drawing



P.C.B. Layout

Specification

APPROVAL



Electrical

Standard
Rated voltage
Rated current
Withstanding voltage
Wire range

cULus	VDE
300V	300V
8A	10A
1.6KV	2.5KV
28-16 AWG	

Mechanical

Ambient temperature
Screw, Torque
Strip length

-40°C ~ +115°C
M2, 0.2Nm (1.7Lb-In.)
6 ~ 7mm

Dimensions

Pitch
Poles

3.50mm
2P - 24P

Material

Housing
Metal housing
Wire guard
Terminal screw

Thermoplastic (UL94V-0)
Brass (CuZn)
PhBz (CuSn)
Steel Zinc



Certification



Pluggable Terminal Block /
Pitch 3.50mm

Part No.: A14G063

DRW:	Justin	CHKD	Frank	MATL:	Jordan	TOLERANCE	Lord	Date	10.02.2009
APPD:	Pete			FINISH	Mike			Sheet No.	1 from 3

www.edcon-components.com

email: info@edcon-components.com



Ordering Informations

Serie	-	No. of Pole	Body-Color	-	Customer Request
A14G063	-	XX	XX	-	X
		XX = total	WH - white		
		02	GN - green		
		...	GR - gray		
		24	TP - transparent		
			OR - orange		
			BK - black		
			BL - blue		
			RD - red		
			YW - yellow		
		PG - Phoenix Green			



Certification



Pluggable Terminal Block / Pitch 3.50mm	
Part No.:	A14G063
Customer:	

DRW:	Justin	CHKD	Frank	MATL:	Jordan	TOLERANCE	Lord	Date	10.02.2009
APPD:	Pete			FINISH	Mike			Sheet No.	2 from 3



Soldering - Profil

Classification Reflow Profile (JEDEC J-STD-020C)

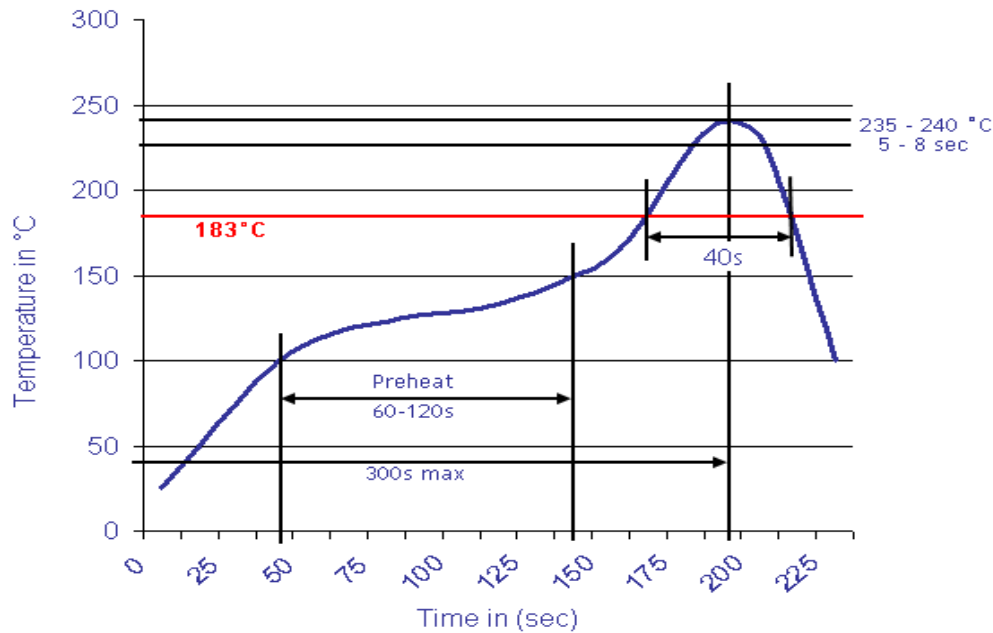

Pluggable Terminal Block /
Pitch 3.50mm

Part No.: A14G063

Customer:

DRW:	Justin	CHKD	Frank	MATL:	Jordan	TOLERANCE	Lord	Date	10.02.2009
APPD:	Pete			FINISH	Mike			Sheet No.	3 from 3