



DATA SHEET

CHIP Low Leakage Current

Serie: I15004

Voltage: 35Volt Range: 47 μ F

Impedance: 5,5 Ω Dimension 6,3x7,7mm

Ripple Current: 110mA

CHIP Low Leakage Current

Serie No.: **I15004**

Customer:

DRW:	Jason	CHKD	Wilson	MATL:	Wilson	TOLERANCE	Mason	DATE	03.06.2014
APPD:	Schumi			FINISH	Jamy		Sheet No.		1 from 7

EDCON-COMPONENTS



Designed for surface mounting on high density circuit board

Emboss carrier tape packing systems is available for automatic insertion



Technical Informations

Voltage:	35Volt
Range;	47µF
Dimension; D x L mm	6,3x7,7mm
Impedance (Ω) max., at20°C, 100hKz	5,5Ω
Ripple Current (mA rms) at 105°C, 100kHz	110mA

Ordering Code			
350	Voltage		
470	Range		
D=	C	L=	3

- Low Leakage current (0,5µA to 3,3µA max).
- Low cost for replacement of some tantalum applications
- Low Impedance with Operating Temperatur Range of -40°C ~ +85°C
- Load Life of 2000hours

Leakage current max.	I = 0,002CV or 0,5µA whichever is greater (after 2 minutes)	
-----------------------------	--	--

Capacitance tolerance	± 20% at 120Hz, 20°C											
Dissipation factor max. (at 120Hz, 20°C)	WV											
	Tanδ	Ø4 ~ Ø6,3mm	6,3	10	16	25	35	50				
			0,24	0,20	0,16	0,14	0,12	0,10				

Low Temperatur characteristics (Impedance ratio at 120Hz)	WV											
		Z-25°C / Z+20°C	6,3	10	16	25	35	50				
		Z-40°C / Z+20°C	4	3	2	2	2	2				
			8	6	4	4	3	3				

Load Life (after application of the rated voltage for 2000hrs at 85°C	Leakage current	Less than specified value
	Capacitance Change	Within ±25% of initial value
	Tanδ	Less than 200% of specified value
	Ø4 ~ Ø6,3x5,4: 1000hours	

CHIP Low Leakage Current	
Part No.:	I15004

DRW:	Jason	CHKD	Wilson	MATL:	Wilson	TOLERANCE	Mason	DATE	03.06.2014	Customer:
APPD:	Schumi			FINISH	Jamy		Sheet No.	2 from 7		

EDCON-COMPONENTS



Designed for surface mounting on high density circuit board
 Emboss carrier tape packing systems is available for automatic insertion



Resistance to soldering heat	After reflow soldering and resistance at room temperature, they meet the characteristics requirements listed at underside	
	Leakage current	Less than specified value
	Capacitance Change	Within $\pm 10\%$ of initial value
	Tan δ	Less than specified value

FREQUENCY COEFFICIENT OF PERMISSIBLE RIPPLE CURRENT					
Frequency	50Hz	120Hz	300Hz	1KHz	10KHz \leq
Coefficient	0,70	1,00	1,17	1,36	1,50

CHIP Low Leakage Current
Part No.: I15004
Customer:

DRW:	Jason	CHKD	Wilson	MATL:	Wilson	TOLERANCE	Mason	DATE	03.06.2014
APPD:	Schumi			FINISH	Jamy		Sheet No.		3 from 7

EDCON-COMPONENTS



Designed for surface mounting on high density circuit board

Emboss carrier tape packing systems is available for automatic insertion



Technical Drawing

Dimension of Size Ø 8x10,5 ~ 16mm



Dimension of Size Ø 4~ 8x6,2mm

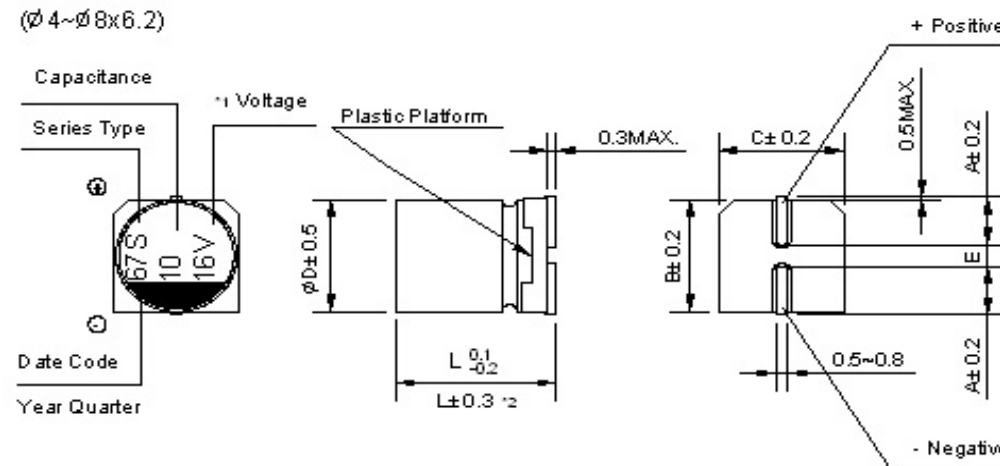

D x L	Ø 4 x 5,4	Ø 5 x 5,4	Ø 6,3 x 5,4	Ø 6,3 x 7,7						
A	2,0	2,2	2,6	2,6						
B	4,3	5,3	6,6	6,6						
C	4,3	5,3	6,6	6,6						
E +/-0.2	1,0	1,3	1,9	1,9						
L	5,4	5,4	5,4	7,7						

*1 Voltage mark (6V) represents 6,3V for Ø 4 ~ 10mm

*3 (L +/- 0.5) is applicable to Ø 8x10,5 ~ Ø 10mm

*2 (L +/- 0.3) is applicable to Ø 6,3 ~ 7.7 and Ø 8 + 6,2mm

*4 (L +/- 1.0) is applicable to Ø 12,5 ~ Ø 16mm

RE. Date code and seriew type -1st digit for Year 2nd digit for Quarter, 4 quarter codes in one year area 1,4,7,0

3rd character for Serie S

CHIP Low Leakage Current

Part No.: **I15004**

DRW:	Jason	CHKD	Wilson	MATL:	Wilson	TOLERANCE	Mason	DATE	03.06.2014	Customer:
APPD:	Schumi			FINISH	Jamy		Sheet No.	4 from 7		

www.edcon-components.com

email: info@edcon-components.com

EDCON-COMPONENTS



Designed for surface mounting on high density circuit board

Emboss carrier tape packing systems is available for automatic insertion



Voltage Ordering Code	Code
4,0	4V0
6,3	6V3
10	100
16	160
25	250
35	350
50	500
63	630
80	800
100	101

Diameter ordering Code D	Code
3mm	3
4mm	A
5mm	B
6,3mm	C
8mm	E
10mm	G
12,5mm	I
16mm	K

Height ordering Code L	Code
4mm	A
5,4mm	0
5,8mm	1
6,2mm	2
7,7mm	3
10,5mm	4
13,5mm	5
16mm	6
16,5mm	7

CHIP Low Leakage Current	
Part No.:	I15004
Customer:	

DRW:	Jason	CHKD	Wilson	MATL:	Wilson	TOLERANCE	Mason	DATE	03.06.2014
APPD:	Schumi			FINISH	Jamy		Sheet No.		5 from 7

EDCON-COMPONENTS



Designed for surface mounting on high density circuit board

Emboss carrier tape packing systems is available for automatic insertion



Ordering Informations

Serie	Voltage Code	Tolerance Code	Range Code	Size Code D	Size Code L	Special function	ROHS	Packing Code		
-------	--------------	----------------	------------	-------------	-------------	------------------	------	--------------	--	--

I15004	350	M	470	C	3	XX	R	TR		
---------------	------------	----------	------------	----------	----------	-----------	----------	-----------	--	--

look table	M= ±20%	Ordering Code Range	Look table Code D	Look table Code L	XX= No function	R= ROHS Conform	TR= Tape Reel Packing		
Voltage Code						N= NON ROHS Conform			
							BU= Bulk-Ware		

CHIP Low Leakage Current

Part No.: **I15004**

DRW:	Jason	CHKD	Wilson	MATL:	Wilson	TOLERANCE	Mason	DATE	03.06.2014
APPD:	Schumi			FINISH	Jamy		Sheet No.		6 from 7

Customer:

EDCON-COMPONENTS



Designed for surface mounting on high density circuit board
 Emboss carrier tape packing systems is available for automatic insertion



Soldering Profile Curve

Classification Reflow Profile (JEDEC J-STD-020C)



CHIP Low Leakage Current	
Part No.:	I15004
Customer:	

DRW:	Jason	CHKD	Wilson	MATL:	Wilson	TOLERANCE	Mason	DATE	03.06.2014
APPD:	Schumi			FINISH	Jamy		Sheet No.	7 from 7	