

# EDCON-COMPONENTS

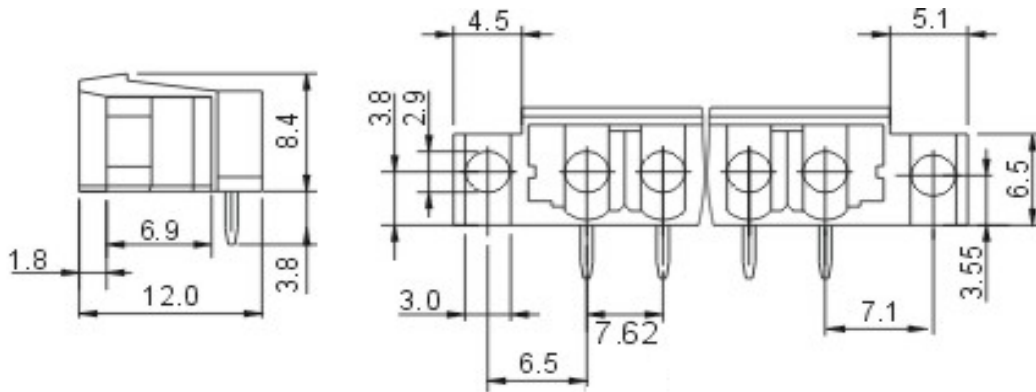

## Drawing



## Specification

### Electrical

Standard	UL	IEC
Rated voltage	300V	320V, 400V
Rated current	15A	20A
Withstanding voltage	AC 2500V/1min	

### Mechanical

Ambient temperature	-40°C ~ +105°C
---------------------	----------------

### Dimensions

Pitch	7.62mm
Poles	2P - 24P   2P - 12P

### Material

Housing	PA66 (UL94V-0)
Pin header	Brass, Tin plated

## P.C.B. Layout

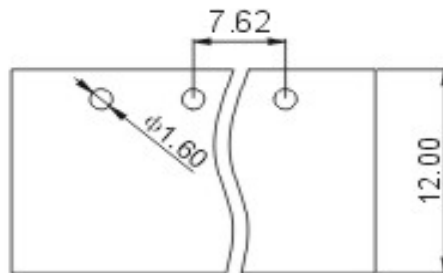

Pluggable Terminal Block /  
Pitch 7.62mm

Part No.: A14R020

Customer:

DRW:	Bill	CHKD	Lord	MATL:	Jimmy	TOLERANCE	Sam	DATE	14.3.2009
APPD:	Louis			FINISH	Georg		Sheet No.		1 from 3

[www.edcon-components.com](http://www.edcon-components.com)

email: [info@edcon-components.com](mailto:info@edcon-components.com)

# EDCON-COMPONENTS



## Ordering Informations

Serie	-	No. of Pole	Body-Color	-	Customer Request
<b>A14R020</b>	-	<b>XX</b>	<b>XX</b>	-	<b>X</b>

XX = total	<b>WH</b> - white
02	<b>GN</b> - green
...	<b>GR</b> - gray
24	<b>LG</b> - light gray
	<b>PG</b> - Phoenix Green
	<b>OR</b> - orange
	<b>BL</b> - blue
	<b>BK</b> - black



Pluggable Terminal Block /  
Pitch 7.62mm

Part No.: A14R020

Customer:

DRW:	Bill	CHKD	Lord	MATL:	Jimmy	TOLERANCE	Sam	DATE	14.3.2009
APPD:	Louis			FINISH	Georg			Sheet No.	2 from 3

[www.edcon-components.com](http://www.edcon-components.com)

email: [info@edcon-components.com](mailto:info@edcon-components.com)

# EDCON-COMPONENTS



## Soldering - Profil

### Classification Reflow Profile (JEDEC J-STD-020C)



Pluggable Terminal Block /  
Pitch 7.62mm

Part No.: A14R020

Customer:

DRW:	Bill	CHKD	Lord	MATL:	Jimmy	TOLERANCE	Sam	DATE	14.3.2009
APPD:	Louis			FINISH	Georg		Sheet No.	3 from 3	

[www.edcon-components.com](http://www.edcon-components.com)

email: [info@edcon-components.com](mailto:info@edcon-components.com)