

# EDCON-COMPONENTS

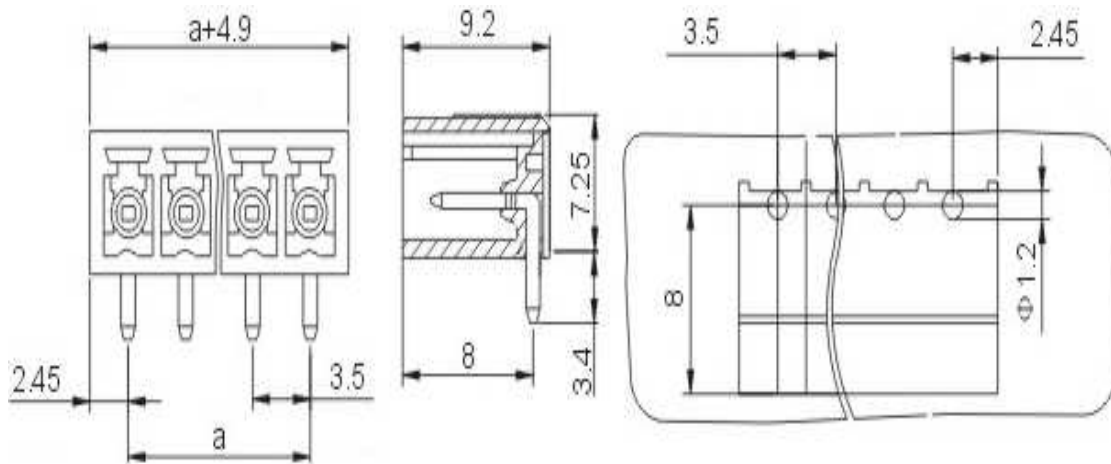

## Drawing



## P.C.B. Layout

## Specification

### Electrical

Standard  
Rated voltage  
Rated current  
Withstanding voltage

UL	IEC
300V	250V
8A	7A
AC 2000V/1min	

### Mechanical

Ambient temperature

-40°C ~ +140°C

### Dimensions

Pitch  
Poles

3.50mm  
2P - 12P

### Material

Housing  
Pin header

PA46 (UL94V-0)  
Brass, Tin plated



Pluggable Terminal Block /

Pitch 3.50mm

Part No.: A14G086

Customer:

DRW:	Justin	CHKD	Frank	MATL:	Jordan	TOLERANCE	Lord	Date	10.02.2009
APPD:	Pete			FINISH	Mike			Sheet No.	1 from 3

[www.edcon-components.com](http://www.edcon-components.com)

email: [info@edcon-components.com](mailto:info@edcon-components.com)

# EDCON-COMPONENTS



## Ordering Informations

Serie	-	No. of Pole	Body-Color	-	Customer Request
-------	---	-------------	------------	---	------------------

A14G086	-	XX	XX	-	X
		XX = total	WH - white		
		02	GN - green		
		...	GR - gray		
		12	TP - transparent		
			OR - orange		
			BK - black		
			BL - blue		
			RD - red		
			YW - yellow		
			PG - Phoenix Green		



Pluggable Terminal Block / Pitch 3.50mm	
Part No.:	A14G086
Customer:	

DRW:	Justin	CHKD	Frank	MATL:	Jordan	TOLERANCE	Lord	Date	10.02.2009
APPD:	Pete			FINISH	Mike			Sheet No.	2 from 3

[www.edcon-components.com](http://www.edcon-components.com)

email: [info@edcon-components.com](mailto:info@edcon-components.com)



## Soldering - Profil

### Classification Reflow Profile (JEDEC J-STD-020C)

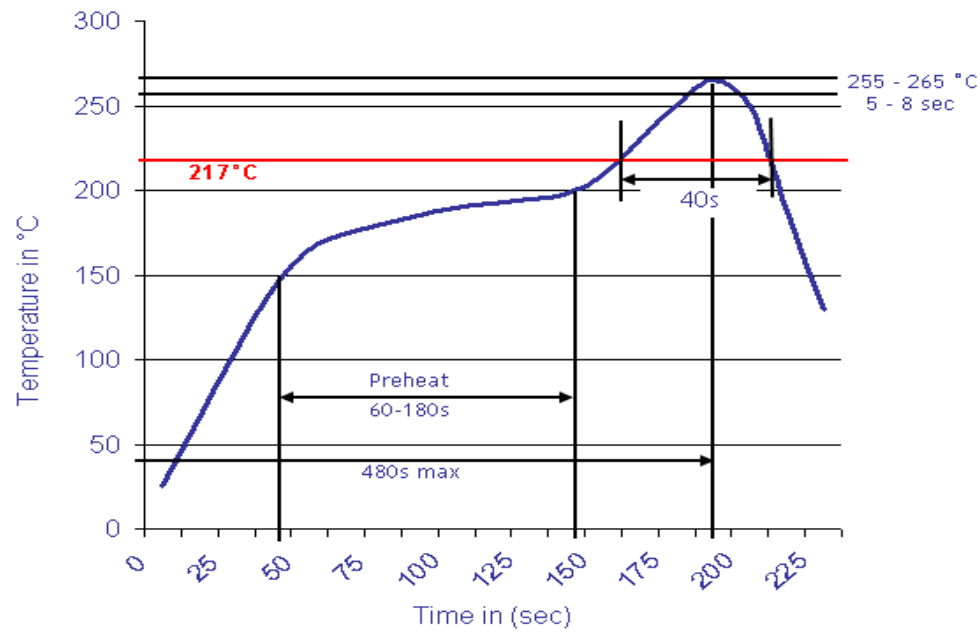

Pluggable Terminal Block /  
Pitch 3.50mm

Part No.: A14G086

Customer:

DRW:	Justin	CHKD	Frank	MATL:	Jordan	TOLERANCE	Lord	Date	10.02.2009
APPD:	Pete			FINISH	Mike			Sheet No.	3 from 3