



Serie T11069

Technical Specifications:

Dielectric Strength:
Insulation Resistance:
Contact Resistance:
Heat Resistance:
Forming Strength of Contact and Body:
Strength of Screw Mounting:
Impact Test:
Rating:
Lifetime:

AC 2500V-60Sec..50~60Hz between Poles
between Poles les by DC500V Min 1000 M Ohm
Attached to Power Connector Max 50 M @ AT 10A
100 +/- 5°C for 1 Hrs.
Static Load of 10 Pounds / 60Sec.
Rotational Torque of 8KG/CM. 5Sec.
0,5KG 1 Times According to UI1950
250VAC / 10A (2,5A)
5000Cycles

Technical Drawing:

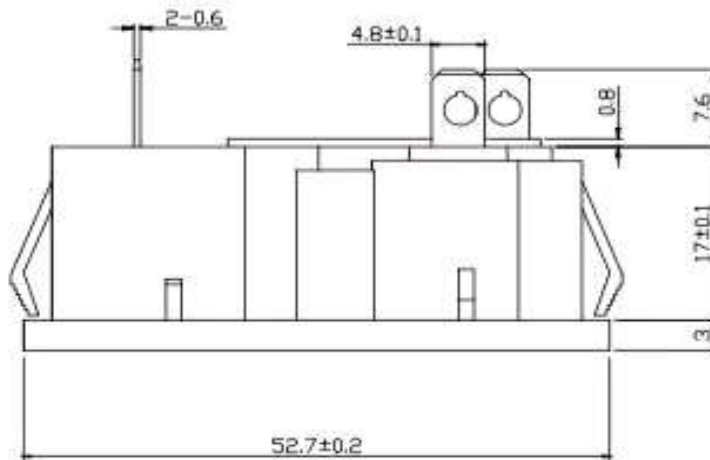
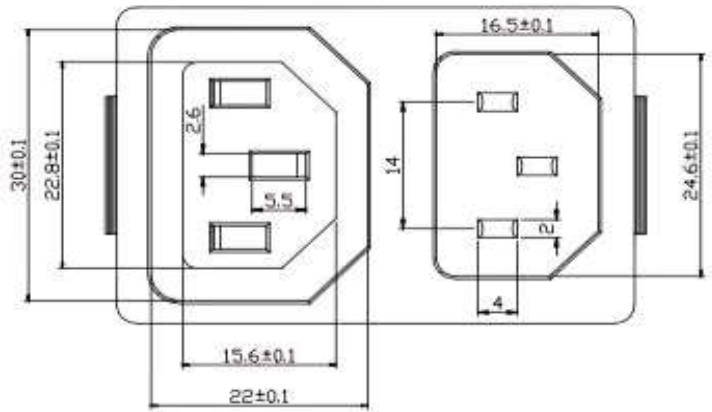
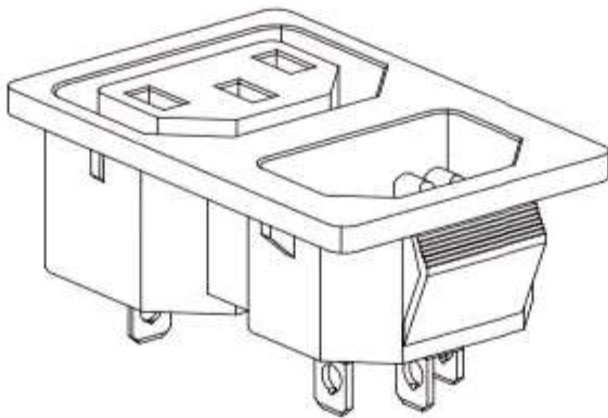

Serie T11069



Serie T11069

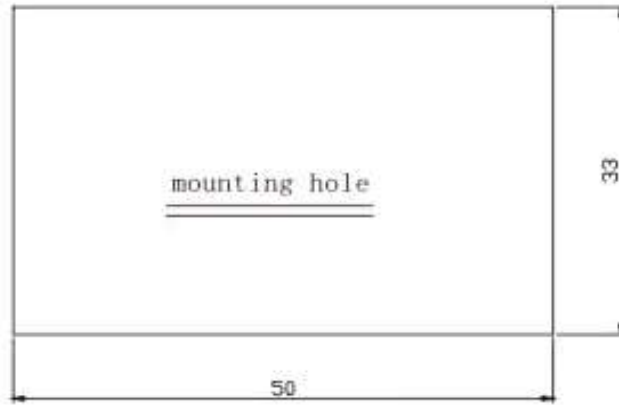

Serie T11069

Ordering Informations:

Serie	Terminal	Colour	Special	Special	R	Verpackung
T11069	A	BK	N	N	N	BU
A= 4,8mm		BK= Black	N= No Special	N= No Special	N= NON ROHS R= ROHS Conform	BU= Bulk-Ware Box