



# DATA SHEET

## SMD Round Nut Size M3

**Serie: N45019**

**SMD Round Nut Size M3**

Serie No.: **N45019**

Customer:

DRW:	Jason	CHKD	Wilson	MATL:	Wilson	TOLERANCE	Mason	DATE	12.08.2024
APPD:	Schumi			FINISH	Jamy		Sheet No.		1 from 13



### Technical Informations

Thread Size: M3  
 Body Material: Steel  
 Surface: Tin Plated  
 Solder Paste Thickness: 150µm  
 Pic and Place Pad Mat.: KAPTON

### Technical Dimensions (mm)

### PCB-Pad Size Dimension

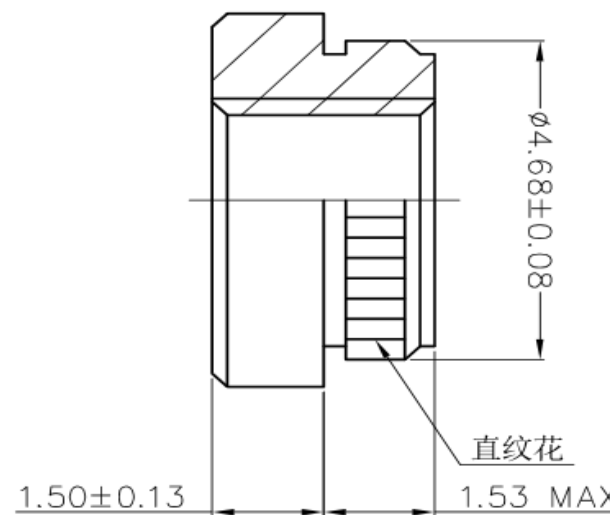
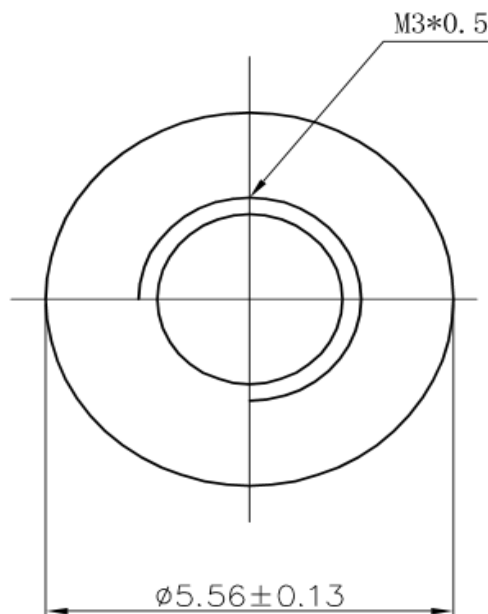

Tolerances unless otherwise specified (mm)				
x	x.X	x.XX	x.XXX	Angle
±	±	±	±	±3°

<b>SMD Round Nut Size M3</b>	
Part No.:	<b>N45019</b>
Customer:	

DRW:	Jason	CHKD:	Wilson	MATL:	Wilson	TOLERANCE:	Mason	DATE:	12.08.2024
APPD:	Schumi			FINISH:	Jamy			Sheet No.:	2 from 13

# EDCON-COMPONENTS



## Ordering Informations

Serie	Special function	Thread Size	Material Code	Surface Plating	Special function	Special function	Special function	ROHS	Packing Code	
<b>N45019</b>	<b>000</b>	<b>M30</b>	<b>SS</b>	<b>TN</b>	<b>N</b>	<b>N</b>	<b>N</b>	<b>R</b>	<b>BU</b>	
	<b>M30=</b> Thread M3,0mm	<b>S0=</b> Steel	<b>TN=</b> Tin Plated	<b>N=</b> No function	<b>N=</b> No function	<b>N=</b> No function	<b>R=</b> ROHS Conform <b>N=</b> NON ROHS Conform	<b>BU=</b> Bulk-Ware <b>TR=</b> Tape Reel Packing		

<b>SMD Round Nut Size M3</b>
Part No.: <b>N45019</b>
Customer:

DRW:	Jason	CHKD	Wilson	MATL:	Wilson	TOLERANCE	Mason	DATE	12.08.2024
APPD:	Schumi			FINISH	Jamy		Sheet No.		12 from 13



Soldering Profile Curve

Classification Reflow Profile (JEDEC J-STD-020C)

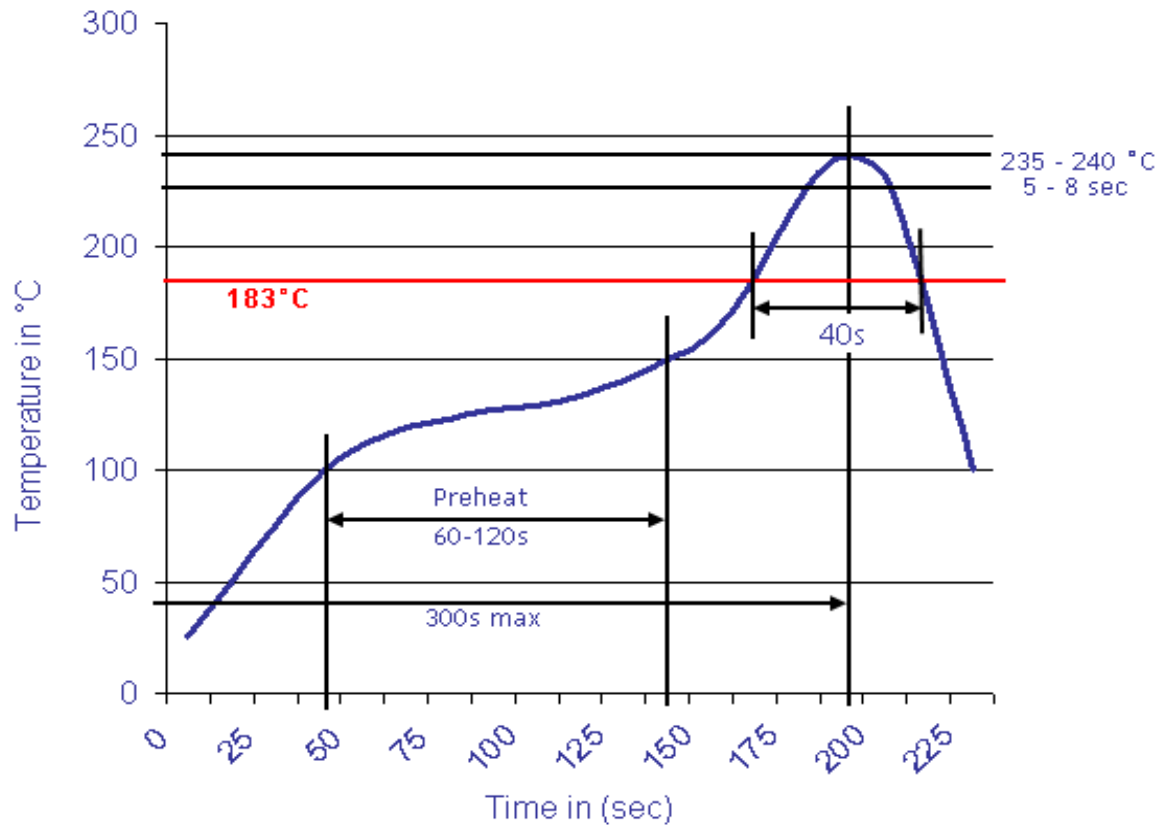

<b>SMD Round Nut Size M3</b>
Part No.: <b>N45019</b>
Customer:

DRW:	Jason	CHKD:	Wilson	MATL:	Wilson	TOLERANCE:	Mason	DATE:	12.08.2024
APPD:	Schumi			FINISH:	Jamy		Sheet No.:		13 from 13