

Data Sheet

Screwless Terminal Block Pitch 5,00mm

Pitch: 5,00 mm

Serie: A11L114

Customer Information for special Item

EDCON Customer : 0

Customer Version No. : 0

EDCON-COMPONENTS

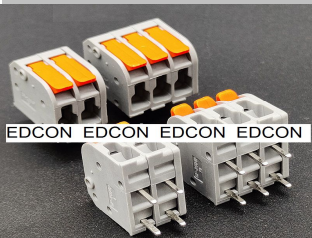

Technical Discription

Electrical	UL	IEC
Rated Voltage	300Volt	450Volt
Rated Current	20A	32A
Wire Range		0,2~4,0mm ²
Wire Range AWG-Size	24~12AWG	
Withstanding Voltage		1,6KV
Insulation Resistance		5000MΩ / 1000V
Mechanical		
Operating Temperature		-40°C ~ +105°C
Wire Strip Length		9-11mm
Dimensions		
Pitch (mm)		5,00
Poles		1 ~ 24 Pos.
Materials		
Terminal Housing		PA66 / UL94V-0
Solder Pin		Copper Alloy / Tin Plated
Solder Pin Diameter:		1,6mm
Cage		Stainless Steel

Drawing (Dimension in mm)

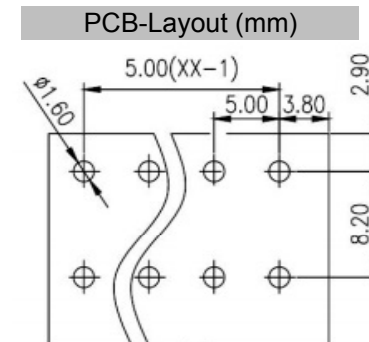
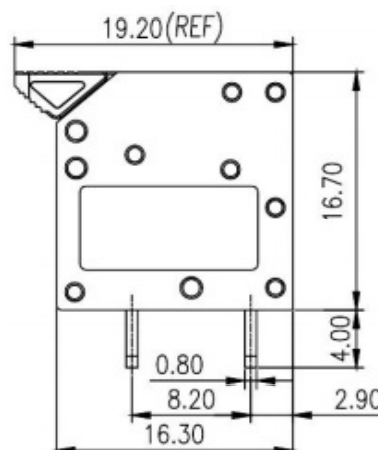
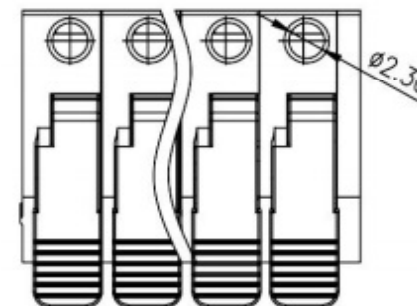
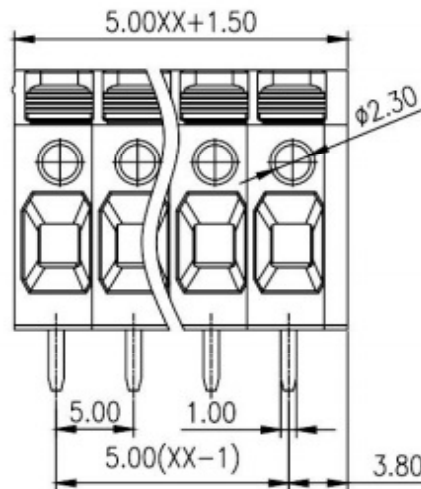

Screwless Terminal Block Pitch 5,00mm

Part No.: **A11L114**

Customer:

DRW:	Jason	CHKD	Wilson	MATL:	Wilson	TOLERANCE	Mason	DATE	28.09.2023
APPD:	Schumi			FINISH	Jamy		Sheet No.		1 from 3

www.edcon-components.com

email: info@edcon-components.com

EDCON-COMPONENTS

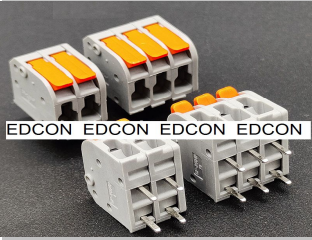

Ordering Informations

Serie	No. of Pos.	Body Color	Screw Type	Approval Code	ROHS	Packing	EDCON Cust. No.	Customer Version		
A11L114	01	GY	C	N	R	B				

Pitch
5,00

01 = Number of Pos.			N = NON Approval	R = ROHS Conform	B = Bulk-Ware	xxxxxx = Customer Number	xxx = Customer Version ??(Printing)
Standard 1 ~ 24Pos.			A = UL /UR Approval Please consult EDCON for available	N = NON ROHS Conform	I = Individual Package		
	GN = Green	C = Screwless Type	B = VDE Approval Please consult EDCON for available	C = TÜV Approval Please consult EDCON for available	1 = Approval for Material		
	GY = Gray						
	BL = Blue						
	BK = Black						

Screwless Terminal Block Pitch 5,00mm	
Part No.:	A11L114
Customer:	

DRW:	Jason	CHKD	Wilson	MATL:	Wilson	TOLERANCE	Mason	DATE	28.09.2023
APPD:	Schumi			FINISH	Jamy		Sheet No.		2 from 3

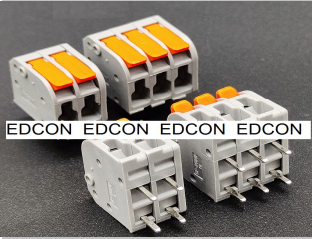

Soldering Profile Curve

Classification Reflow Profile (JEDEC J-STD-020C)

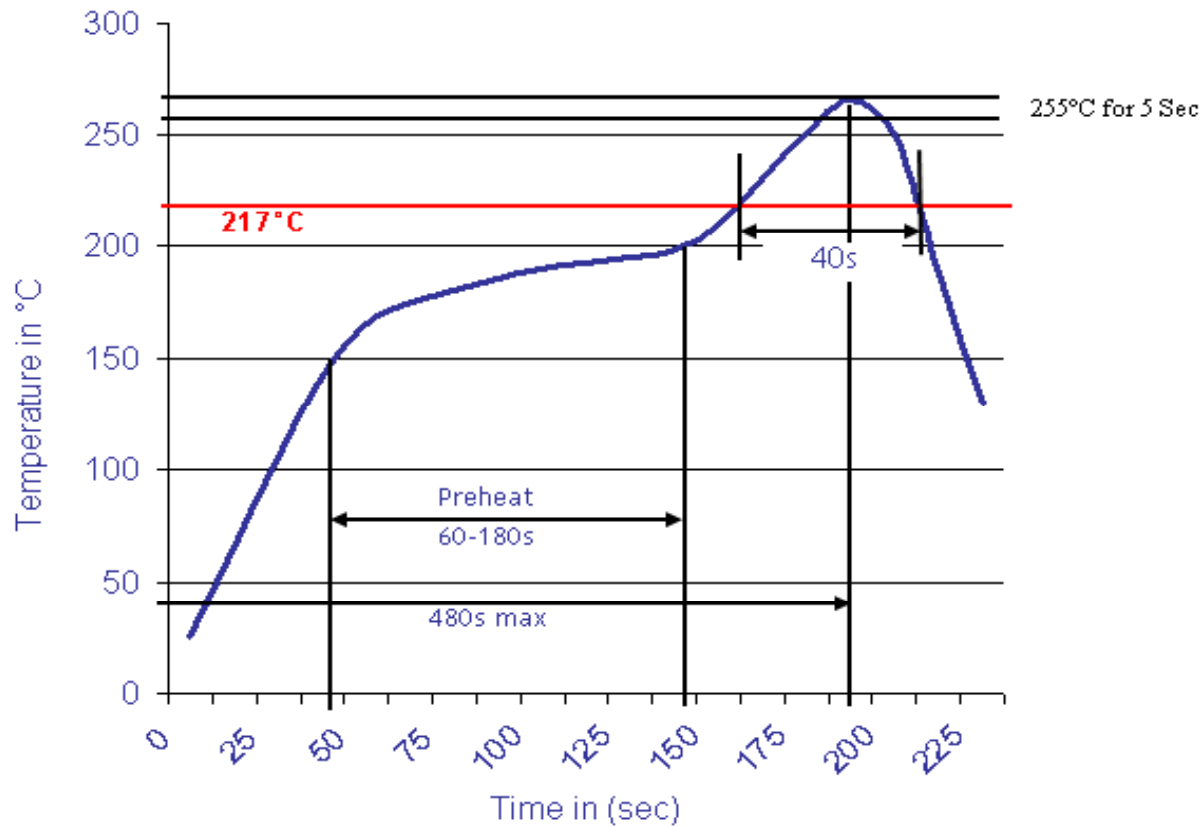

**Screwless Terminal Block
Pitch 5,00mm**

Part No.: **A11L114**

DRW:	Jason	CHKD:	Wilson	MATL:	Wilson	TOLERANCE	Mason	DATE	28.09.2023
APPD:	Schumi			FINISH	Jamy		Sheet No.	3 from 3	

Customer: