

# Data Sheet

## Screwless Terminal Block Pitch 5,00mm

**Pitch: 5,00 mm**

**Serie: A11L113**

### Customer Information for special Item

**EDCON Customer : 0**

**Customer Version No. : 0**

# EDCON-COMPONENTS

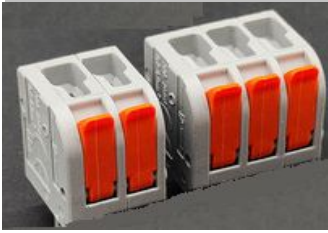

## Technical Discription

Electrical	UL	IEC
Rated Voltage	300Volt	450Volt
Rated Current	20A	32A
Wire Range		0,2~4,0mm <sup>2</sup>
Wire Range AWG-Size	24~12AWG	
Withstanding Voltage		1,6KV
Insulation Resistance		5000MΩ / 1000V
Mechanical		
Operating Temperature		-40°C ~ +105°C
Wire Strip Length		9-11mm
Dimensions		
Pitch (mm)		5,00
Poles		1 ~ 24 Pos.
Materials		
Terminal Housing		PA66 / UL94V-0
Solder Pin		Copper Alloy / Tin Plated
Solder Pin Diameter:		1,6mm
Cage		Stainless Steel

## Drawing (Dimension in mm)

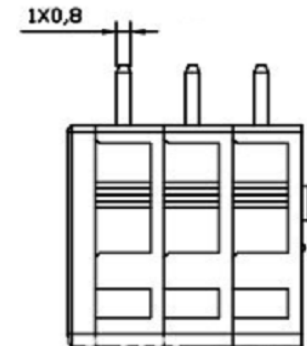
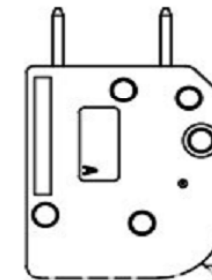
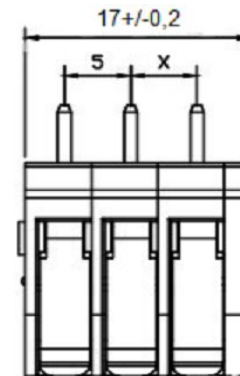
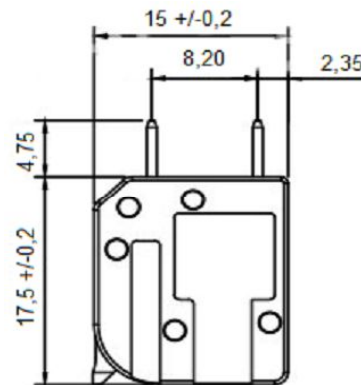
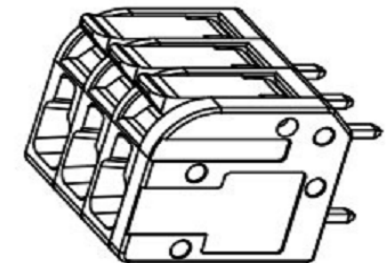
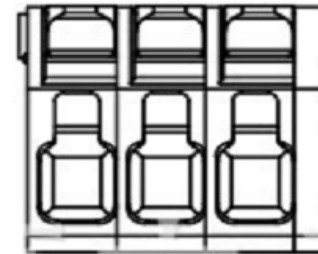

**Screwless Terminal Block  
Pitch 5,00mm**

Part No.: **A11L113**

DRW:	Jason	CHKD	Wilson	MATL:	Wilson	TOLERANCE	Mason	DATE	28.09.2023
APPD:	Schumi			FINISH	Jamy		Sheet No.		1 from 3

Customer:

[www.edcon-components.com](http://www.edcon-components.com)

email: [info@edcon-components.com](mailto:info@edcon-components.com)

# EDCON-COMPONENTS

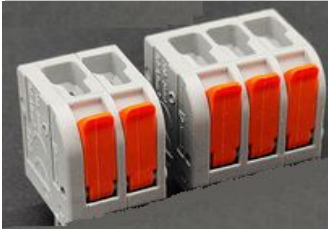

## Ordering Informations

Serie	No. of Pos.	Body Color	Screw Type	Approval Code	ROHS	Packing	EDCON Cust. No.	Customer Version		
<b>A11L113</b>	<b>01</b>	<b>GY</b>	<b>C</b>	<b>N</b>	<b>R</b>	<b>B</b>				

Pitch  
5,00

<b>01</b> = Number of Pos.			<b>N</b> = NON Approval	<b>R</b> = ROHS Conform	<b>B</b> = Bulk-Ware	<b>xxxxxx</b> = Customer Number	<b>xxx</b> = Customer Version ??(Printing)
Standard 1 ~ 24Pos.			<b>A</b> = UL /UR Approval Please consult EDCON for available	<b>N</b> = NON ROHS Conform	<b>I</b> = Individual Package		
	<b>GN</b> = Green	<b>C</b> = Screwless Type	<b>B</b> = VDE Approval Please consult EDCON for available	<b>C</b> = TÜV Approval Please consult EDCON for available			
	<b>GY</b> = Gray						
	<b>BL</b> = Blue						
	<b>BK</b> = Black						
			<b>1</b> = Approval for Material				

**Screwless Terminal Block  
Pitch 5,00mm**

Part No.: **A11L113**

DRW:	Jason	CHKD	Wilson	MATL:	Wilson	TOLERANCE	Mason	DATE	28.09.2023	Customer:
APPD:	Schumi			FINISH	Jamy		Sheet No.	2 from 3		

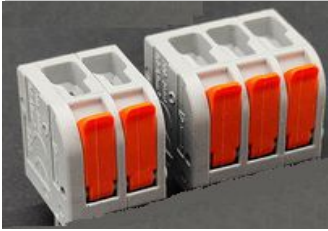

Soldering Profile Curve

Classification Reflow Profile (JEDEC J-STD-020C)

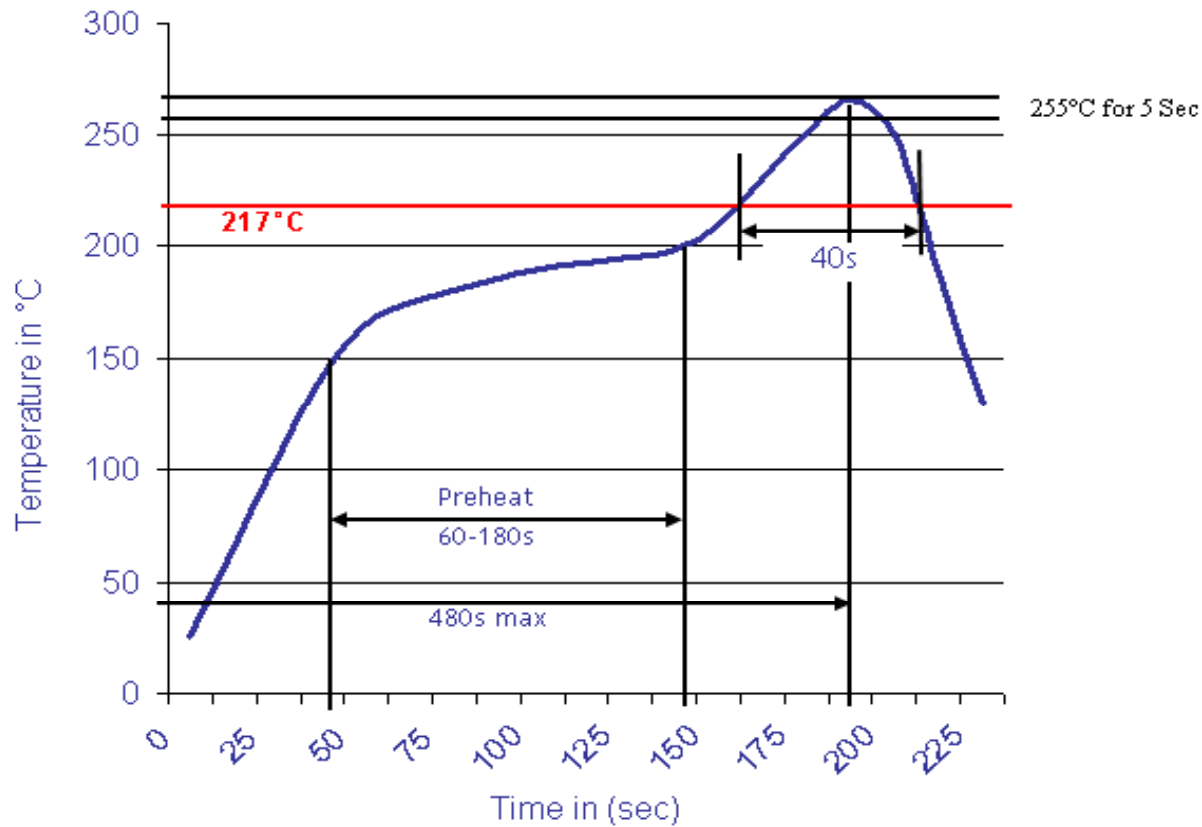

<b>Screwless Terminal Block</b>	
<b>Pitch 5,00mm</b>	
Part No.:	<b>A11L113</b>
Customer:	

DRW:	Jason	CHKD:	Wilson	MATL:	Wilson	TOLERANCE:	Mason	DATE:	28.09.2023
APPD:	Schumi			FINISH:	Jamy		Sheet No.		3 from 3