

Data Sheet

Screwless Terminal Block Pitch 5,00mm

Pitch: 5.00 mm

Serie: A11L099

Customer Information for special Item

EDCON Customer : xxxxxx

Customer Version No. : xx

EDCON-COMPONENTS

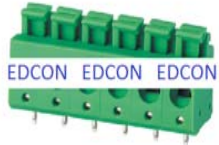

Technical Description

Electrical:

Rated voltage:
Rated current:
Withstanding Voltage: AC/1min:
Operating Temperature:

UL	IEC	VDE
300V	250V	
10A	10A	
2000V	2000V	

-40°C ~ +105°C

Mechanical:

Strip length: mm
Wire range: Solid wire: AWG
Wire range: Stranded wire: AWG

8-9mm	8-9mm	
24-14	1,5mm ²	

Material:

Housing Terminal Body: PA66 UL94V-0
Housing Left-side: PA66 UL94V-0
Housing Right side: PA66 UL94V-0
Lever:
Terminal: Copper Matte Tin plated over Nickel
Spring Clamp: Stainless steel

Drawing (Dimension in mm)

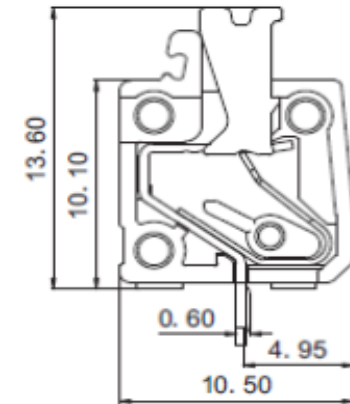
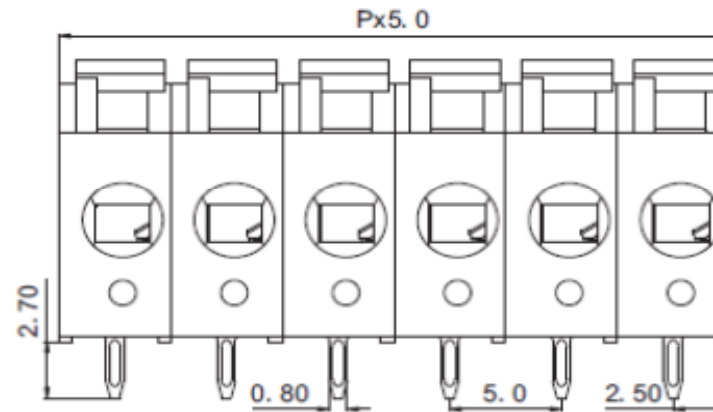

Item No.		
1		
2		
3		
4		
5		
6		
7		
8		
9		

Tolerances unless otherwise specified (mm)				
X	X.X	X.XX	X.XXX	Angle
±	±	±	±	±3°
DRW:	Jason	CHKD	Wilson	MATL:
APPD:	Schumi			FINISH

Screwless Terminal Block Pitch 5,00mm	
Part No.:	A11L099
Customer:	

DRW:	Jason	CHKD	Wilson	MATL:	Wilson	TOLERANCE	Mason	DATE	30.11.2020
APPD:	Schumi			FINISH	Jamy			Sheet No.	1 from 4

EDCON-COMPONENTS



PCB Layout Dimension (mm)
TOP-VIEW

Dimensions (mm)

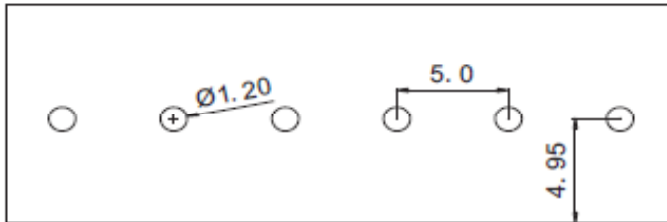

Frontside

**Screwless Terminal Block Pitch
5,00mm**

Part No.: **A11L099**

DRW:	Jason	CHKD	Wilson	MATL:	Wilson	TOLERANCE	Mason	DATE	30.11.2020
APPD:	Schumi			FINISH	Jamy		Sheet No.	2 from 4	Customer:

www.edcon-components.com

email: info@edcon-components.com

EDCON-COMPONENTS

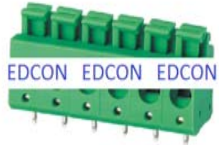

Ordering Informations

Serie	No. of Pos.	Body Color	Srew Type	Approval Code	ROHS	Packing	EDCON Cust. No.	Customer Version		
A11L099	01	PG	C	N	R	B	xxxxxx	xx		

Pitch 5.00

01 = Number of Pos.		C = Screwless Type	N = NON Approval	R = ROHS Conform	B = Standard Package Box/ Polybag	xxxxxx = Customer Number	xx = Customer Version (Printing) ??
Standard 1 ~ 24Pos.			1 = UL-Approval for Body Material	N = NON ROHS Conform	I = Individual Package		
			A = UL /UR Approval Please consult EDCON for available				
			B = VDE Approval Please consult EDCON for available				
			C = TÜV Approval Please consult EDCON for available				
		PG = Phoenix Green					

Screwless Terminal Block Pitch 5,00mm
Part No.: A11L099
Customer:

DRW:	Jason	CHKD	Wilson	MATL:	Wilson	TOLERANCE	Mason	DATE	30.11.2020
APPD:	Schumi			FINISH	Jamy		Sheet No.		3 from 4

www.edcon-components.com

email: info@edcon-components.com



Soldering Profile Curve

Classification Reflow Profile (JEDEC J-STD-020C)

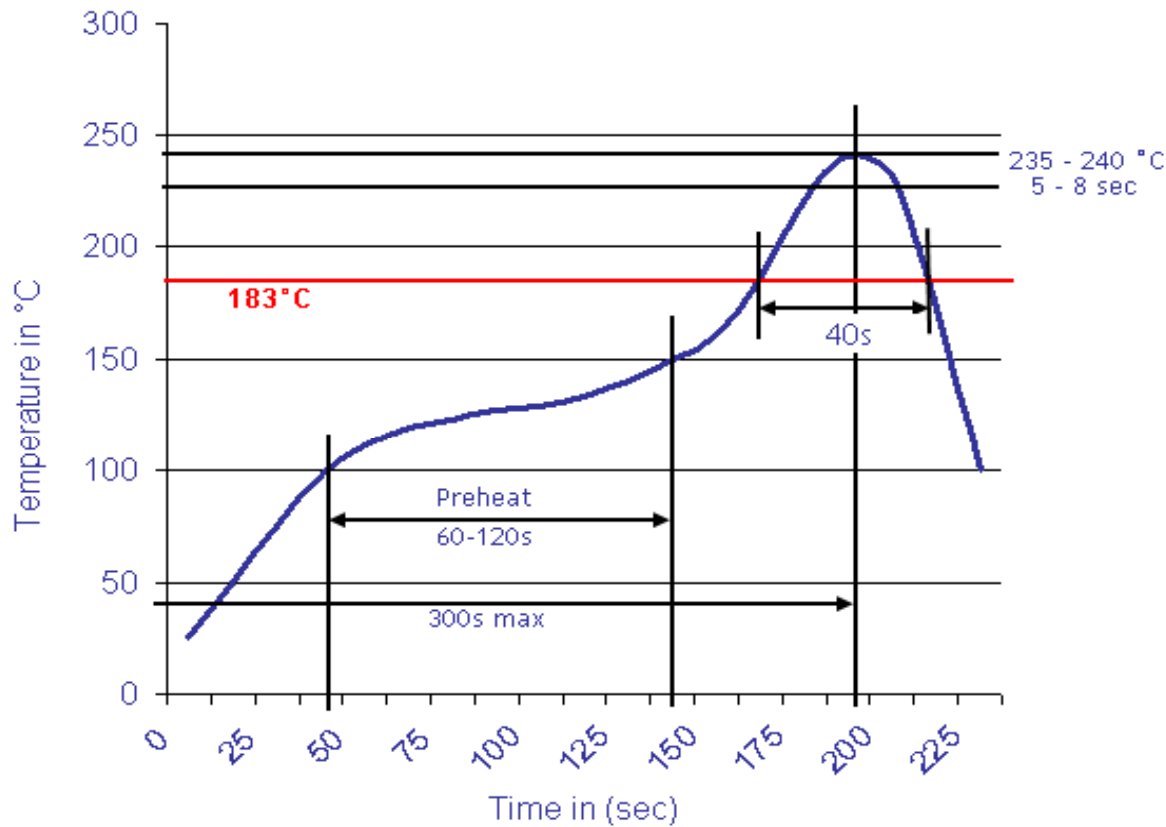

Screwless Terminal Block Pitch 5,00mm	
Part No.:	A11L099
Customer:	

DRW:	Jason	CHKD	Wilson	MATL:	Wilson	TOLERANCE	Mason	DATE	30.11.2020
APPD:	Schumi			FINISH	Jamy		Sheet No.	4 from 4	