

Data Sheet

Screwless Terminal Block Pitch 5,00mm

Pitch: 5.00 mm

Serie: A11L097

Customer Information for special Item

EDCON Customer : xxxxxx

Customer Version No. : xx

EDCON-COMPONENTS



Technical Discription

Electrical:

Rated voltage:
Rated current:
Withstanding Voltage: AC/1min:
Operating Temperature:

UL	IEC	VDE
300V	250V	
8A	15A	
2000V	2000V	
-40°C ~ +105°C		

Mechanical:

Strip length: mm
Wire range: Solid wire: AWG
Wire range: Stranded wire:AWG

8-9mm	8-9mm	
20-16	1,5mm ²	

Material:

Housing Terminal Body: PA66 UL94V-0
Housing Left-side: PA66 UL94V-0
Housing Right side: PA66 UL94V-0
Lever:
Terminal: Copper Matte Tin plated over Nickel
Spring Clamp: Stainless steel

Drawing (Dimension in mm)

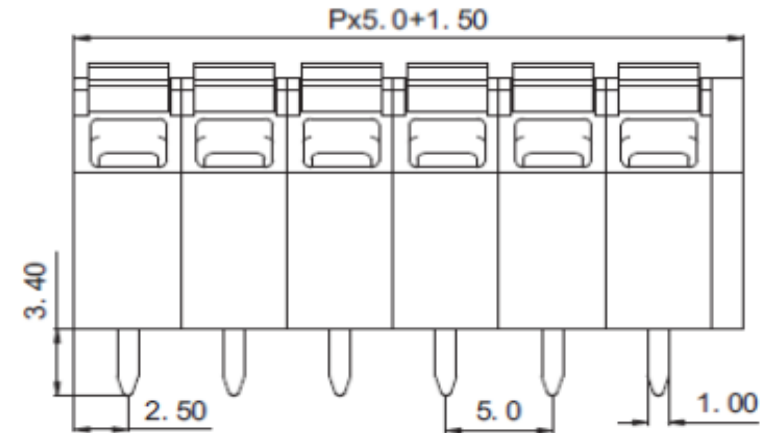
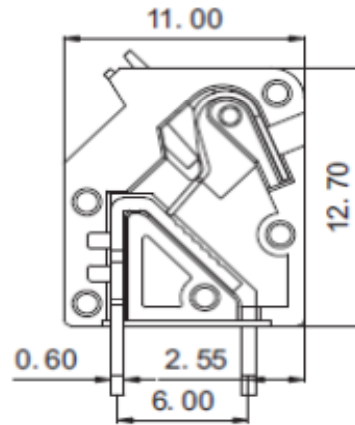

Item No.		
1		
2		
3		
4		
5		
6		
7		
8		
9		

Tolerances unless otherwise specified (mm)				
X	X.X	X.XX	X.XXX	Angle
±	±	±	±	±3°
DRW:	Jason	CHKD	Wilson	MATL:
APPD:	Schumi			FINISH
		Mason		DATE
		Jamy		30.11.2020
			Sheet No.	1 from 4

Screwless Terminal Block Pitch 5,00mm	
Part No.:	A11L097
Customer:	

DRW:	Jason	CHKD	Wilson	MATL:
APPD:	Schumi			FINISH

EDCON-COMPONENTS



PCB Layout Dimension (mm)
TOP-VIEW

Dimensions (mm)

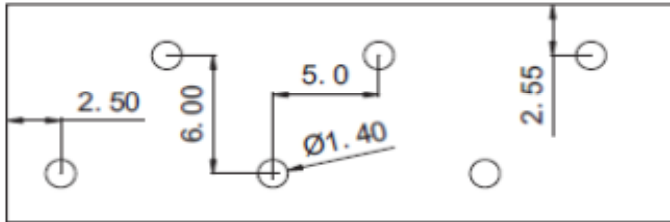

Frontside

**Screwless Terminal Block Pitch
5,00mm**

Part No.: **A11L097**

DRW:	Jason	CHKD	Wilson	MATL:	Wilson	TOLERANCE	Mason	DATE	30.11.2020
APPD:	Schumi			FINISH	Jamy		Sheet No.	2 from 4	

Customer:

EDCON-COMPONENTS



Ordering Informations

Serie	No. of Pos.	Body Color	Srew Type	Approval Code	ROHS	Packing	EDCON Cust. No.	Customer Version		
A11L097	02	BK	C	N	R	B	xxxxxx	xx		

Pitch 5.00

02= Number of Pos.		C= Screwless Type	N= NON Approval	R= ROHS Conform	B= Standard Package Box/ Polybag	xxxxxx= Customer Number	xx= Customer Version (Printing) ??
Standard 2 ~ 24Pos.			1= UL-Approval for Body Material	N= NON ROHS Conform	I= Individual Package		
			A= UL /UR Approval Please consult EDCON for available				
			B= VDE Approval Please consult EDCON for available				
			C= TÜV Approval Please consult EDCON for available				
	BK= Black						

Screwless Terminal Block Pitch 5,00mm
Part No.: A11L097
Customer:

DRW:	Jason	CHKD	Wilson	MATL:	Wilson	TOLERANCE	Mason	DATE	30.11.2020
APPD:	Schumi			FINISH	Jamy		Sheet No.		3 from 4

www.edcon-components.com

email: info@edcon-components.com



Soldering Profile Curve

Classification Reflow Profile (JEDEC J-STD-020C)

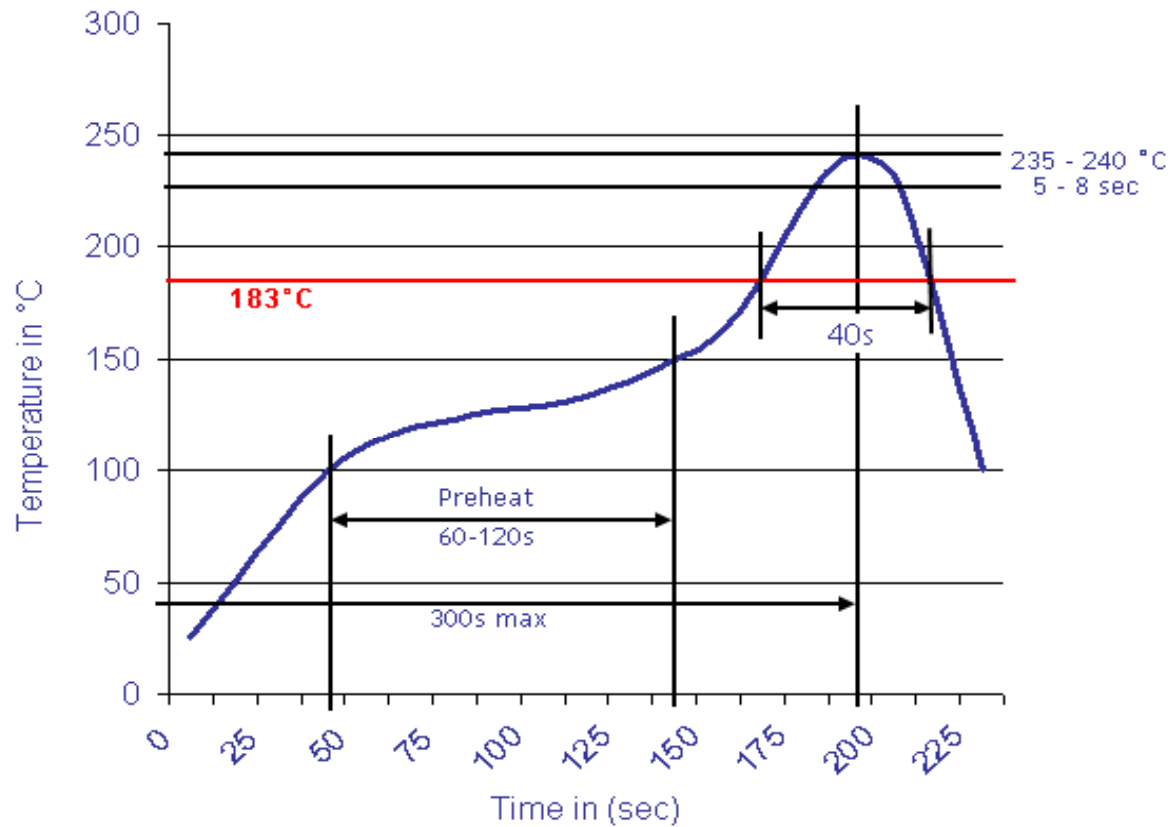

Screwless Terminal Block Pitch 5,00mm	
Part No.:	A11L097
Customer:	

DRW:	Jason	CHKD	Wilson	MATL:	Wilson	TOLERANCE	Mason	DATE	30.11.2020
APPD:	Schumi			FINISH	Jamy		Sheet No.	4 from 4	