

Data Sheet

Screwless Terminal Block Pitch 5,00mm

Pitch: 5,00 mm

Serie: A11L086

Customer Information for special Item

EDCON Customer : xxxxxx

Customer Version No. : xx



PCB Layout Dimension (mm)

PCB-TOP-VIEW

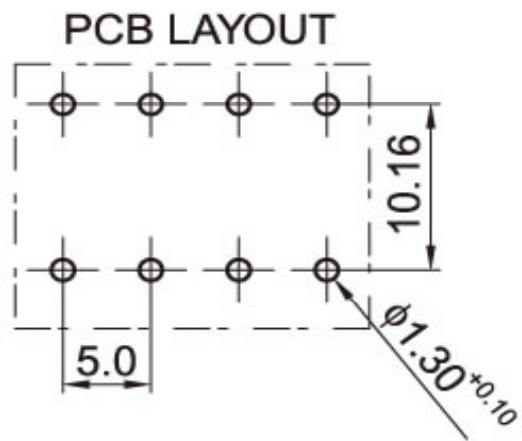

Screwless Terminal Block Pitch 5,00mm	
Part No.:	A11L086
Customer:	

DRW:	Jason	CHKD	Wilson	MATL:	Wilson	TOLERANCE	Mason	DATE	07.03.2019
APPD:	Schumi			FINISH	Jamy		Sheet No.	2 from 4	

EDCON-COMPONENTS



Ordering Informations

Serie	No. of Pos.	Body Color	Srew Type	Approval Code	ROHS	Packing	EDCON Cust. No.	Customer Version		
A11L086	02	GY	C	N	R	B	xxxxxx	xx		

Pitch
5,00

02= Number of Pos. Standard 2 ~ 24Pos.	GY= Gray (Standard)	C= Screwless Type	N= NON Approval 1= UL-Approval for Body Material A= UL /UR Approval Please consult EDCON for available B= VDE Approval Please consult EDCON for available C= TÜV Approval Please consult EDCON for available	R= ROHS Conform N= NON ROHS Conform	B= Standard Package Box/ Polybag I= Individual Package	xxxxxx= Customer Number	xx= Customer Version (Printing) ??
--	----------------------------	--------------------------	---	--	---	--------------------------------	---

Screwless Terminal Block Pitch 5,00mm	
Part No.:	A11L086
Customer:	

DRW:	Jason	CHKD	Wilson	MATL:	Wilson	TOLERANCE	Mason	DATE	07.03.2019
APPD:	Schumi			FINISH	Jamy		Sheet No.		3 from 4



Soldering Profile Curve

Classification Reflow Profile (JEDEC J-STD-020C)

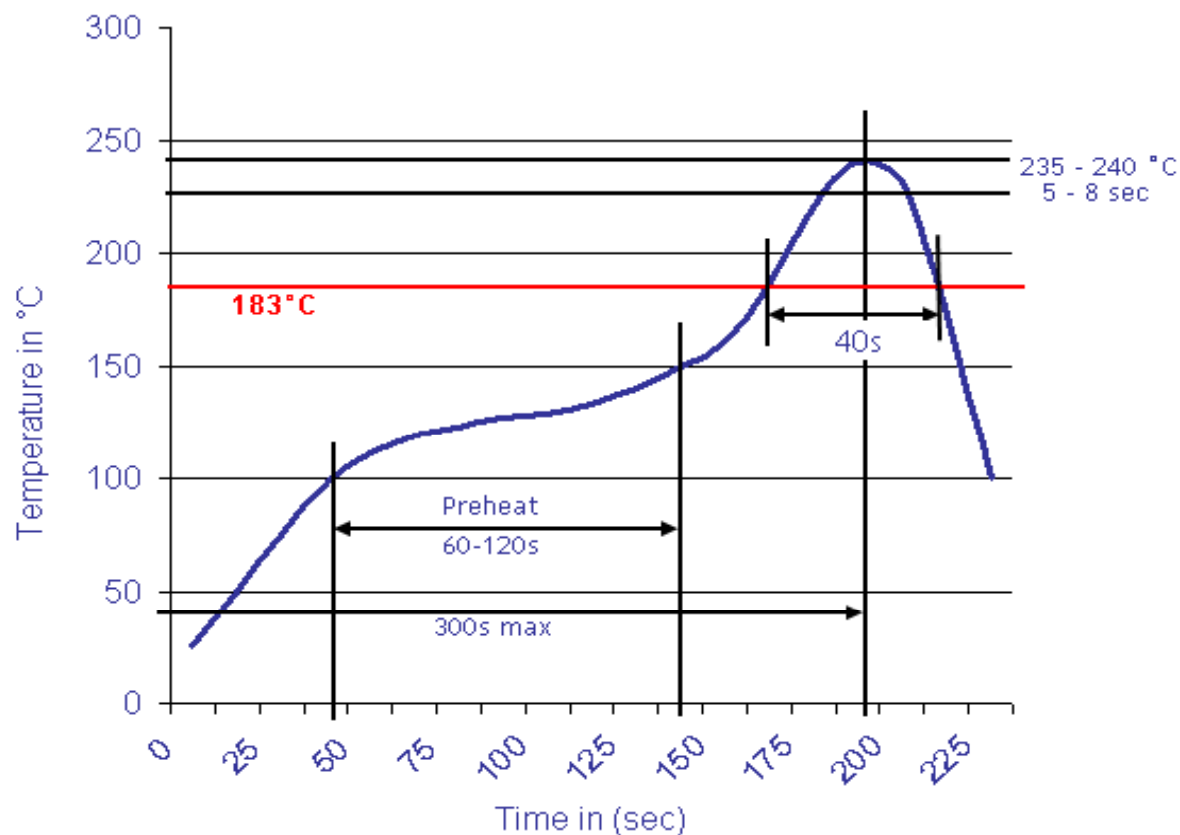

**Screwless Terminal Block Pitch
5,00mm**

Part No.: **A11L086**

Customer:

DRW:	Jason	CHKD	Wilson	MATL:	Wilson	TOLERANCE	Mason	DATE	07.03.2019
APPD:	Schumi			FINISH	Jamy		Sheet No.	4 from 4	

