

Data Sheet

Screwless Terminal Block

Pitch: 5,00 mm

Serie: A11L060

Customer Information for special Item

EDCON Customer : 0

Customer Version No. : 0

EDCON-COMPONENTS



Technical Discription

Drawing (Dimension in mm)

Electrical

Rated voltage	300V
Rated current	10A
Contact resistance	20mΩ
Insulation resistance	5000MΩ / 1000V
Withstanding voltage	AC1500V/Min
Wire range	26-14 AWG / 2.5mm ²

Mechanical

Wire strip length	5 ~ 6mm
Operating temperature	-40°C ~ + 105°C
Soldering temperature	+250°C/Sec

Dimensions

Pitch	5.00mm
Poles	3x (1P - xxP)

Material

Housing	PA66 (UL94V-0)
Pin header	Brass, Tin plated
Wire guard	Stainless steel

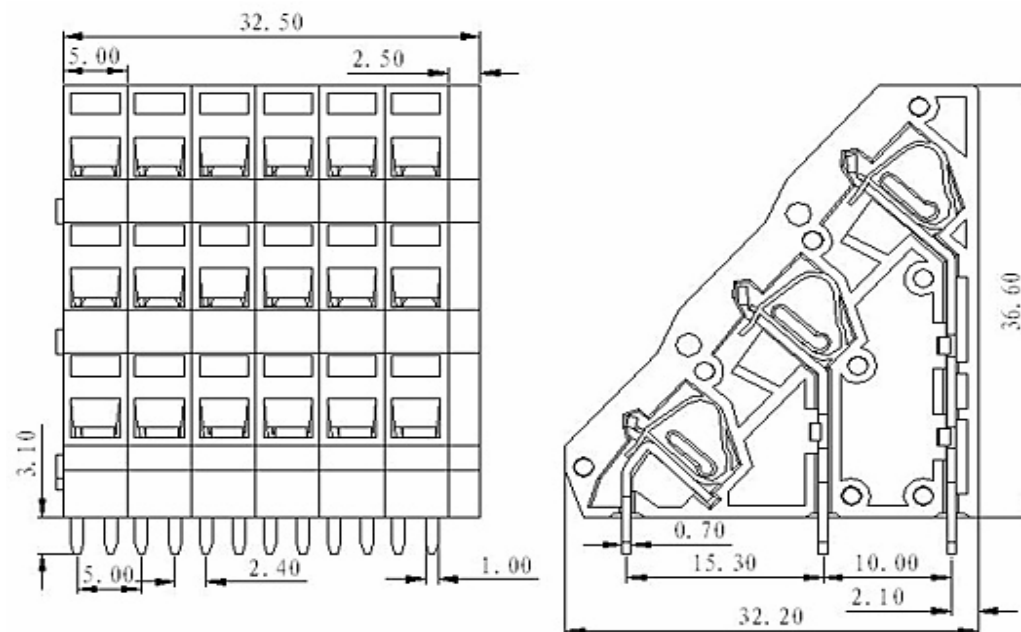

Screwless Terminal Block

Part No.: **A11L060**

Customer:

DRW:	Jason	CHKD	Wilson	MATL:	Wilson	TOLERANCE	Mason	DATE	03.02.2014
APPD:	Schumi			FINISH	Jamy		Sheet No.	1 from 4	

EDCON-COMPONENTS



PCB Layout (Dimension in mm)

Dimensions (mm)

No. of Pos.	A	Tol. P	B	Tol. P
02	12,50	± 0,35	5,00	± 0,35
03	17,50	± 0,35	10,00	± 0,35
04	22,50	± 0,36	15,00	± 0,36
05	27,50	± 0,37	20,00	± 0,37
06	32,50	± 0,38	25,00	± 0,38
07	37,50	± 0,39	30,00	± 0,39
08	42,50	± 0,40	35,00	± 0,40
09	47,50	± 0,41	40,00	± 0,41
10	52,50	± 0,42	45,00	± 0,42
11	57,50	± 0,43	50,00	± 0,43
12	62,50	± 0,44	55,00	± 0,44
13	67,50	± 0,45	60,00	± 0,45
14	72,50	± 0,46	65,00	± 0,46
15	77,50	± 0,47	70,00	± 0,47
16	82,50	± 0,48	75,00	± 0,48
17	87,50	± 0,49	80,00	± 0,49
18	92,50	± 0,50	85,00	± 0,50
19	97,50	± 0,51	90,00	± 0,51
20	102,50	± 0,52	95,00	± 0,52
21	107,50	± 0,53	100,00	± 0,53
22	112,50	± 0,54	105,00	± 0,54
23	117,50	± 0,55	110,00	± 0,55
24	122,50	± 0,56	115,00	± 0,56

Screwless Terminal Block

Part No.: **A11L060**

DRW:	Jason	CHKD	Wilson	MATL:	Wilson	TOLERANCE	Mason	DATE	03.02.2014	Customer:
APPD:	Schumi			FINISH	Jamy		Sheet No.	2 from 4		

EDCON-COMPONENTS



Ordering Informations

Serie	No. of Pos.	Body Color	Approval	Approval Code	ROHS	Packing	EDCON Cust. No.	Customer Version		
-------	-------------	------------	----------	---------------	------	---------	-----------------	------------------	--	--

A11L060	02	GN	N	N	R	B				
----------------	-----------	-----------	----------	----------	----------	----------	--	--	--	--

Pitch 5,00	02 = Number of Pos. Standard 2~24 Pos.	GY = Gray (Standard) GN = Green OR = Orange BK = Black	N = No Approval 1 = Approval for Material 2 = Approval for Terminal Block	N = NON Approval A = UL /UR Approval Please consult EDCON for available B = VDE Approval Please consult EDCON for available C = TÜV Approval Please consult EDCON for available	R = ROHS Conform N = NON ROHS Conform	B = Standard Package I = Individual Package	xxxxxx = Customer Number	xxx = Customer Version ??(Printing)		
---------------	--	---	--	---	--	--	---------------------------------	---	--	--

Screwless Terminal Block

Part No.: **A11L060**

DRW:	Jason	CHKD	Wilson	MATL:	Wilson	TOLERANCE	Mason	DATE	03.02.2014
APPD:	Schumi			FINISH	Jamy		Sheet No.		3 from 4

Customer:



Soldering Profile Curve

Classification Reflow Profile (JEDEC J-STD-020C)



Screwless Terminal Block

Part No.: **A11L060**

Customer:

DRW:	Jason	CHKD	Wilson	MATL:	Wilson	TOLERANCE	Mason	DATE	03.02.2014
APPD:	Schumi			FINISH	Jamy		Sheet No.	4 from 4	

