

Data Sheet

Screwless Terminal Block

Pitch: 5,00 mm

Serie: A11L034

Customer Information for special Item

EDCON Customer : 0

Customer Version No. : 0

EDCON-COMPONENTS

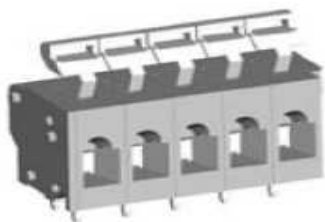

Technical Discription

Drawing (Dimension in mm)

Electrical

Standard	cULus
Rated voltage	300V
Rated current	15A
Solid / Stranded wire	28-14 AWG
Withstanding voltage	1.6KV

Mechanical

Wire strip length	6 ~ 7mm
Ambient temperature	-40°C ~ +115°C
Soldering temperature	250°C ±10°C/5 sec

Dimensions

Pitch	5.00mm
Poles	1P - 24P

Material

Housing	PA66 (UL94V-0)
Pin header	Phosphor Bronze, Tin plated
Wire guard	Stainless steel

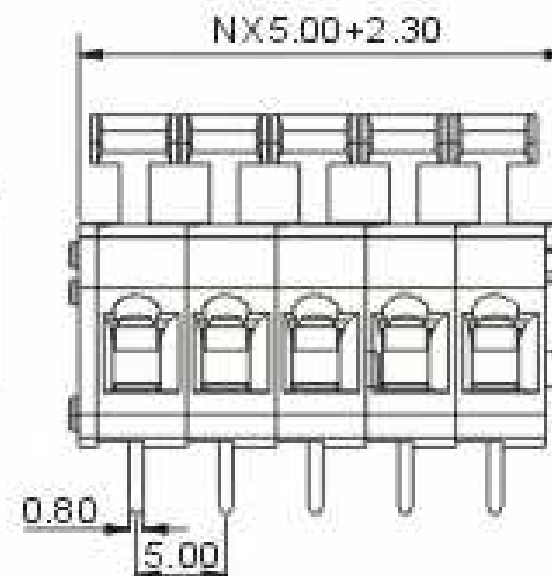
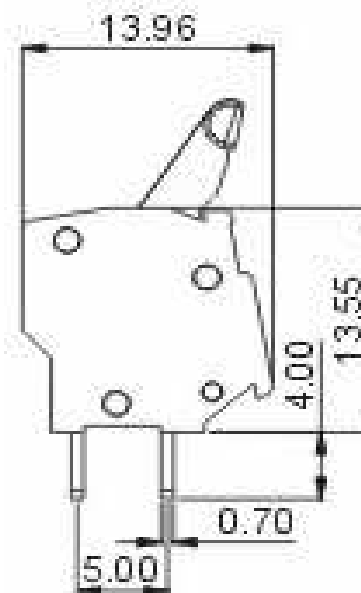

Screwless Terminal Block

Part No.: **A11L034**

Customer:

DRW:	Jason	CHKD	Wilson	MATL:	Wilson	TOLERANCE	Mason	DATE	03.02.2014
APPD:	Schumi			FINISH	Jamy		Sheet No.	1 from 4	

EDCON-COMPONENTS

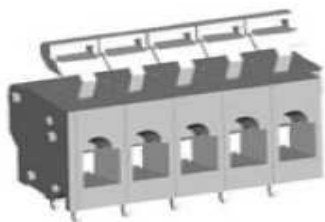

PCB Layout (Dimension in mm)

Dimensions (mm)

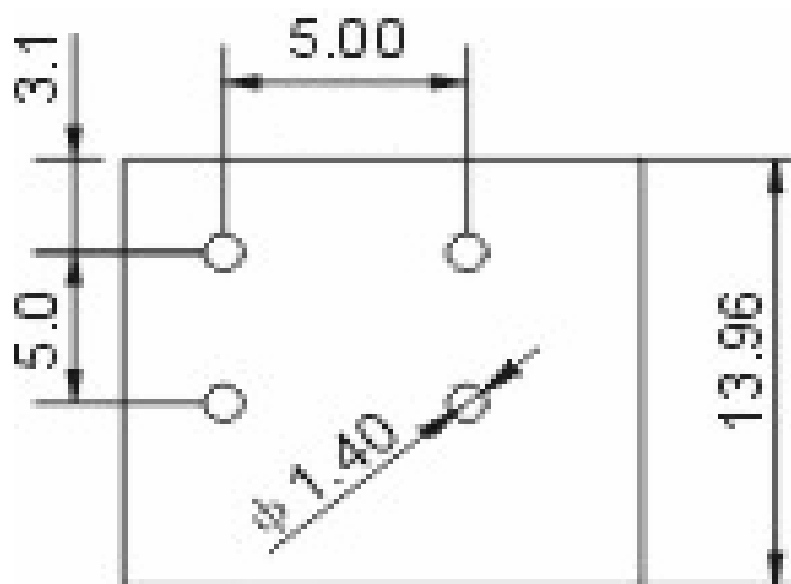

No. of Pos.	A	Tol. P	B	Tol. P
02	12,30	± 0,35	5,00	± 0,35
03	17,30	± 0,35	10,00	± 0,35
04	22,30	± 0,35	15,00	± 0,35
05	27,30	± 0,35	20,00	± 0,35
06	32,30	± 0,35	25,00	± 0,35
07	37,30	± 0,35	30,00	± 0,35
08	42,30	± 0,35	35,00	± 0,35
09	47,30	± 0,35	40,00	± 0,35
10	52,30	± 0,35	45,00	± 0,35
11	57,30	± 0,35	50,00	± 0,35
12	62,30	± 0,35	55,00	± 0,35
13	67,30	± 0,35	60,00	± 0,35
14	72,30	± 0,35	65,00	± 0,35
15	77,30	± 0,35	70,00	± 0,35
16	82,30	± 0,35	75,00	± 0,35
17	87,30	± 0,35	80,00	± 0,35
18	92,30	± 0,35	85,00	± 0,35
19	97,30	± 0,35	90,00	± 0,35
20	102,30	± 0,35	95,00	± 0,35
21	107,30	± 0,35	100,00	± 0,35
22	112,30	± 0,35	105,00	± 0,35
23	117,30	± 0,35	110,00	± 0,35
24	122,30	± 0,35	115,00	± 0,35

Screwless Terminal Block

Part No.: **A11L034**

Customer:

DRW:	Jason	CHKD	Wilson	MATL:	Wilson	TOLERANCE	Mason	DATE	03.02.2014
APPD:	Schumi			FINISH	Jamy		Sheet No.	2 from 4	

EDCON-COMPONENTS

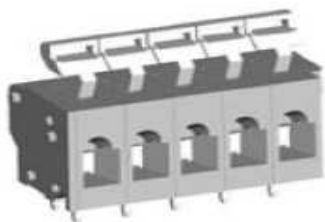

Ordering Informations

Serie	No. of Pos.	Body Color	Approval	Approval Code	ROHS	Packing	EDCON Cust. No.	Customer Version		
-------	-------------	------------	----------	---------------	------	---------	-----------------	------------------	--	--

A11L034	02	GY	N	N	R	B				
----------------	-----------	-----------	----------	----------	----------	----------	--	--	--	--

Pitch 5,00	02 = Number of Pos. Standard 2~24 Pos.	GY = Gray (Standard) GN = Green OR = Orange BK = Black	N = No Approval 1 = Approval for Material 2 = Approval for Terminal Block	N = NON Approval A = UL /UR Approval Please consult EDCON for available B = VDE Approval Please consult EDCON for available C = TÜV Approval Please consult EDCON for available	R = ROHS Conform N = NON ROHS Conform	B = Standard Package I = Individual Package	xxxxxx = Customer Number	xxx = Customer Version ??(Printing)		
---------------	--	---	--	--	--	--	---------------------------------	--	--	--

Screwless Terminal Block

Part No.: **A11L034**

DRW:	Jason	CHKD	Wilson	MATL:	Wilson	TOLERANCE	Mason	DATE	03.02.2014
APPD:	Schumi			FINISH	Jamy		Sheet No.		3 from 4

Customer:

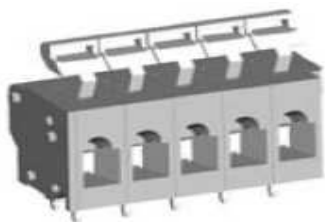

Soldering Profile Curve

Classification Reflow Profile (JEDEC J-STD-020C)

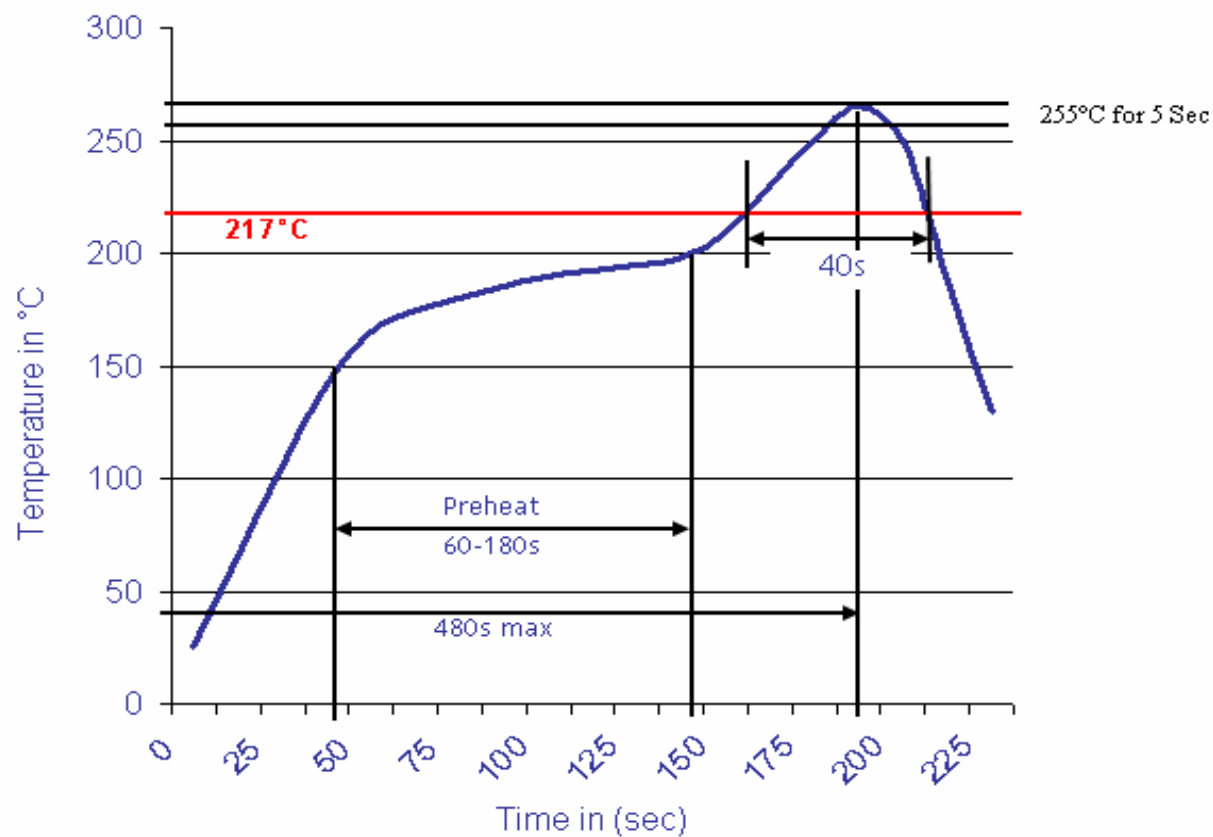

Screwless Terminal Block

Part No.: **A11L034**

Customer:

DRW:	Jason	CHKD	Wilson	MATL:	Wilson	TOLERANCE	Mason	DATE	03.02.2014
APPD:	Schumi			FINISH	Jamy		Sheet No.	4 from 4	

