

Data Sheet

Screwless Terminal Block

Pitch: 5,00 mm

Serie: A11L033

Customer Information for special Item

EDCON Customer : 0

Customer Version No. : 0

EDCON-COMPONENTS



Technical Discription

Drawing (Dimension in mm)

Electrical

Rated voltage	300V
Rated current	25A
Contact resistance	20mΩ
Insulation resistance	5000MΩ / 1000V
Withstand voltage	AC1500V/1Min
Wire range	22-14 AWG / 1.5mm ²

Mechanical

Wire strip length	7 ~ 8mm
Operating temperature	-40°C ~ +105°C
Soldering temperature	+250°C/5sec

Dimensions

Pitch	5.00mm
Poles	2P - 24P

Material

Housing	PA66 (UL94V-0)
Pin header	Brass Tin plated
Wire guard	Stainless steel

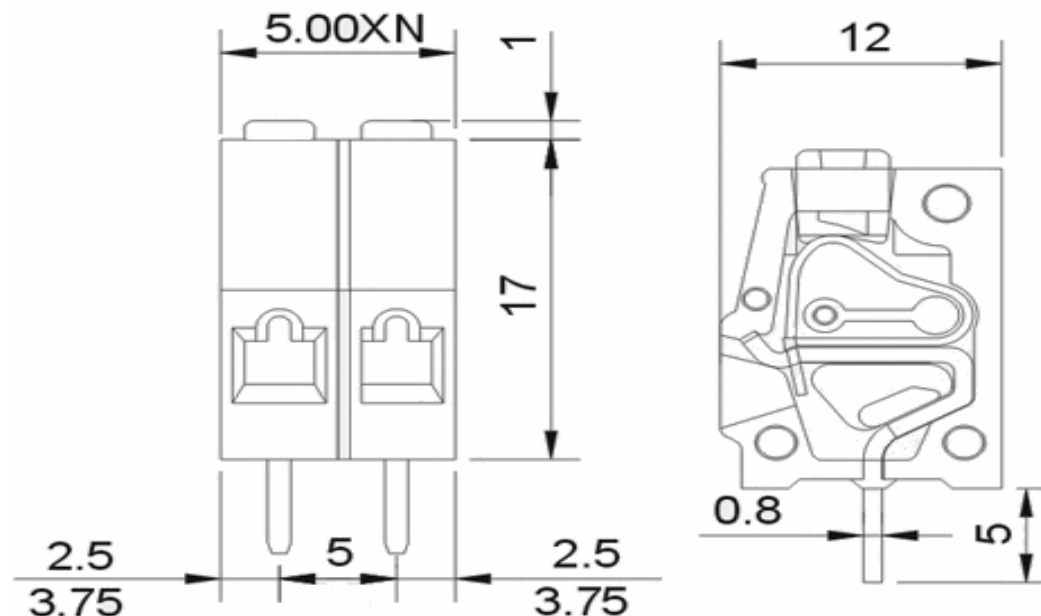

Screwless Terminal Block

Part No.: **A11L033**

Customer:

DRW:	Jason	CHKD	Wilson	MATL:	Wilson	TOLERANCE	Mason	DATE	03.02.2014
APPD:	Schumi			FINISH	Jamy		Sheet No.	1 from 4	

EDCON-COMPONENTS



PCB Layout (Dimension in mm)

Dimensions (mm)

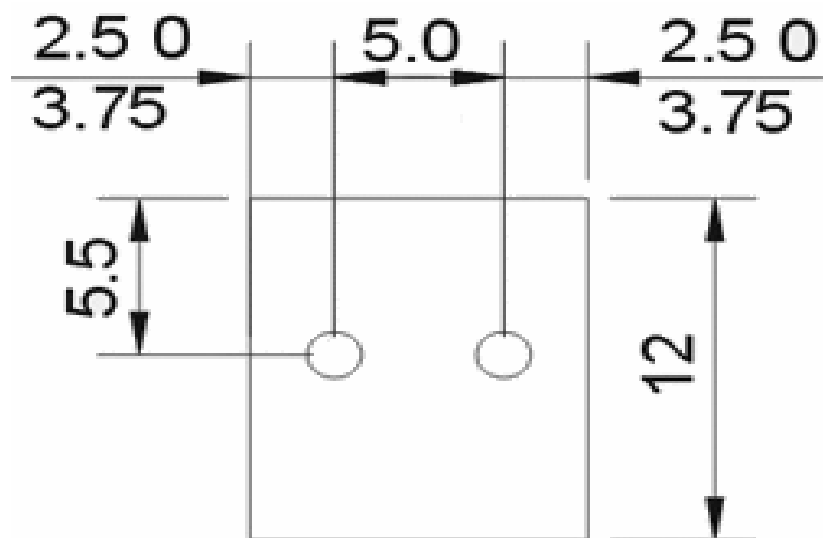

No. of Pos.	A	Tol. P	B	Tol. P
02	10,00	± 0,35	5,00	± 0,35
03	15,00	± 0,35	10,00	± 0,35
04	20,00	± 0,35	15,00	± 0,35
05	25,00	± 0,35	20,00	± 0,35
06	30,00	± 0,35	25,00	± 0,35
07	35,00	± 0,35	30,00	± 0,35
08	40,00	± 0,35	35,00	± 0,35
09	45,00	± 0,35	40,00	± 0,35
10	50,00	± 0,35	45,00	± 0,35
11	55,00	± 0,35	50,00	± 0,35
12	60,00	± 0,35	55,00	± 0,35
13	65,00	± 0,35	60,00	± 0,35
14	70,00	± 0,35	65,00	± 0,35
15	75,00	± 0,35	70,00	± 0,35
16	80,00	± 0,35	75,00	± 0,35
17	85,00	± 0,35	80,00	± 0,35
18	90,00	± 0,35	85,00	± 0,35
19	95,00	± 0,35	90,00	± 0,35
20	100,00	± 0,35	95,00	± 0,35
21	105,00	± 0,35	100,00	± 0,35
22	110,00	± 0,35	105,00	± 0,35
23	115,00	± 0,35	110,00	± 0,35
24	120,00	± 0,35	115,00	± 0,35

Screwless Terminal Block

Part No.: **A11L033**

DRW:	Jason	CHKD	Wilson	MATL:	Wilson	TOLERANCE	Mason	DATE	03.02.2014
APPD:	Schumi			FINISH	Jamy		Sheet No.		2 from 4

Customer:

EDCON-COMPONENTS



Ordering Informations

Serie	No. of Pos.	Body Color	Approval	Approval Code	ROHS	Packing	EDCON Cust. No.	Customer Version		
A11L033	02	GN	N	N	R	B				

Pitch
5,00

02= Number of Pos. Standard 2~24 Pos.	GY= Gray (Standard)	N= No Approval	N= NON Approval	R= ROHS Conform	B= Standard Package	xxxxxx= Customer Number	xxx= Customer Version ??(Printing)
	GN= Green	1= Approval for Material	A= UL /UR Approval Please consult EDCON for available	N= NON ROHS Conform	I= Individual Package		
		2= Approval for Terminal Block	B= VDE Approval Please consult EDCON for available				
	OR= Orange		C= TÜV Approval Please consult EDCON for available				
	BK= Black						

Screwless Terminal Block	
Part No.:	A11L033
Customer:	

DRW:	Jason	CHKD	Wilson	MATL:	Wilson	TOLERANCE	Mason	DATE	03.02.2014
APPD:	Schumi			FINISH	Jamy		Sheet No.		3 from 4



Soldering Profile Curve

Classification Reflow Profile (JEDEC J-STD-020C)

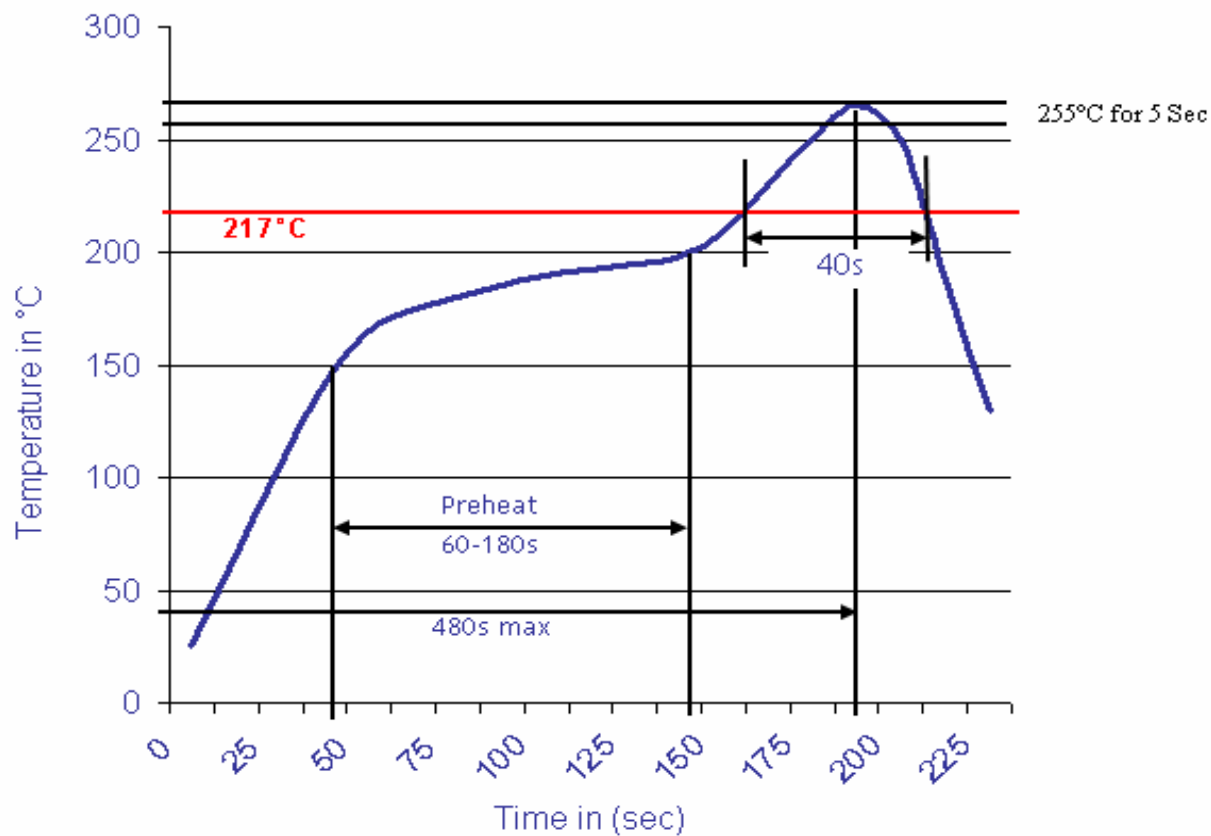

Screwless Terminal Block

Part No.: **A11L033**

Customer:

DRW:	Jason	CHKD	Wilson	MATL:	Wilson	TOLERANCE	Mason	DATE	03.02.2014
APPD:	Schumi			FINISH	Jamy		Sheet No.	4 from 4	

