

Data Sheet

Screwless Terminal Block

Pitch: 5,00 mm

Serie: A11L030

Customer Information for special Item

EDCON Customer : 0

Customer Version No. : 0

EDCON-COMPONENTS

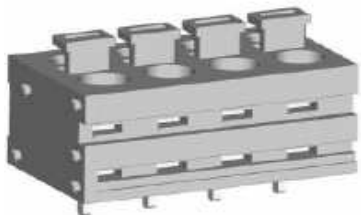

Technical Discription

Drawing (Dimension in mm)

Electrical

Standard	cULus
Rated voltage	300V
Rated current	6A
Solid / Stranded wire	26-16 AWG
Withstanding voltage	1.6KV

Mechanical

Wire strip length	6 ~ 7mm
Ambient temperature	-40°C ~ +115°C
Soldering temperature	250°C ±10°C/5 sec

Dimensions

Pitch	5.00mm
Poles	2P - 24P

Material

Housing	Thermoplastic (UL94V-0)
Pin header	Brass, Tin plated
Wire guard	Stainless steel

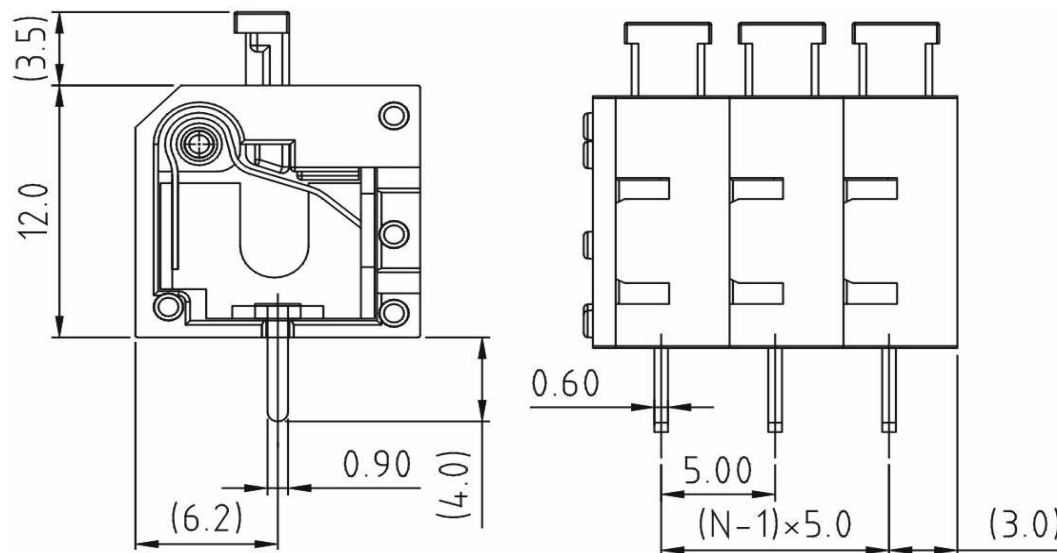

Screwless Terminal Block

Part No.: **A11L030**

Customer:

DRW:	Jason	CHKD	Wilson	MATL:	Wilson	TOLERANCE	Mason	DATE	03.02.2014
APPD:	Schumi			FINISH	Jamy		Sheet No.	1 from 4	

EDCON-COMPONENTS

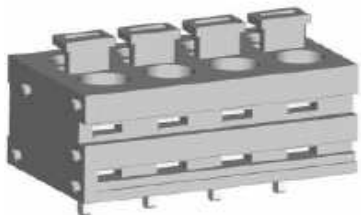

PCB Layout (Dimension in mm)

Dimensions (mm)

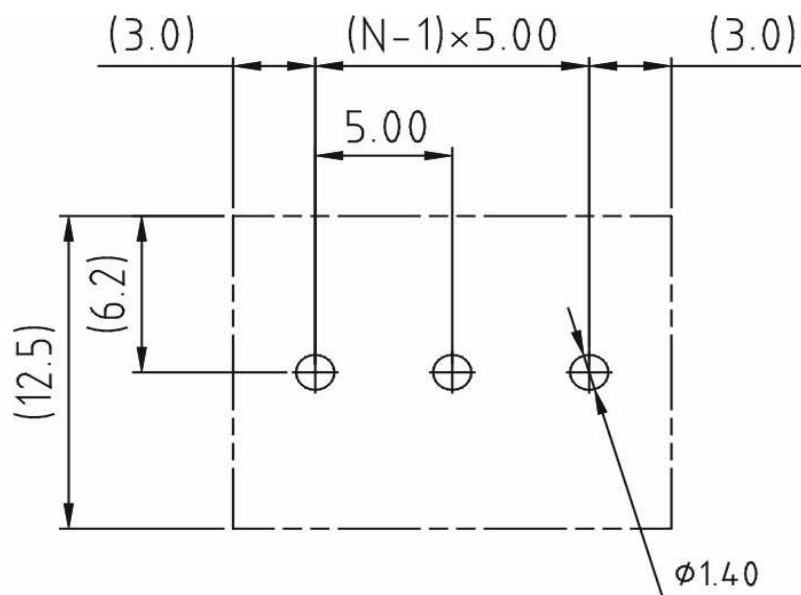

No. of Pos.	A	Tol. P	B	Tol. P
02	11,50	± 0,35	5,00	± 0,35
03	16,50	± 0,35	10,00	± 0,35
04	21,50	± 0,35	15,00	± 0,35
05	26,50	± 0,35	20,00	± 0,35
06	31,50	± 0,35	25,00	± 0,35
07	36,50	± 0,35	30,00	± 0,35
08	41,50	± 0,35	35,00	± 0,35
09	46,50	± 0,35	40,00	± 0,35
10	51,50	± 0,35	45,00	± 0,35
11	56,50	± 0,35	50,00	± 0,35
12	61,50	± 0,35	55,00	± 0,35
13	66,50	± 0,35	60,00	± 0,35
14	71,50	± 0,35	65,00	± 0,35
15	76,50	± 0,35	70,00	± 0,35
16	81,50	± 0,35	75,00	± 0,35
17	86,50	± 0,35	80,00	± 0,35
18	91,50	± 0,35	85,00	± 0,35
19	96,50	± 0,35	90,00	± 0,35
20	101,50	± 0,35	95,00	± 0,35
21	106,50	± 0,35	100,00	± 0,35
22	111,50	± 0,35	105,00	± 0,35
23	116,50	± 0,35	110,00	± 0,35
24	121,50	± 0,35	115,00	± 0,35

Screwless Terminal Block

Part No.: **A11L030**

DRW:	Jason	CHKD	Wilson	MATL:	Wilson	TOLERANCE	Mason	DATE	03.02.2014
APPD:	Schumi			FINISH	Jamy		Sheet No.	2 from 4	Customer:

www.edcon-components.com

email: info@edcon-components.com

EDCON-COMPONENTS

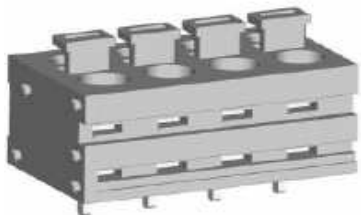

Ordering Informations

Serie	No. of Pos.	Body Color	Approval	Approval Code	ROHS	Packing	EDCON Cust. No.	Customer Version		
A11L030	02	GY	N	N	R	B				

Pitch
5,00

02= Number of Pos. Standard 2~24 Pos.	GY= Gray (Standard)	N= No Approval	N= NON Approval	R= ROHS Conform	B= Standard Package	xxxxxx= Customer Number	xxx= Customer Version ??(Printing)
	GN= Green	1= Approval for Material	A= UL /UR Approval Please consult EDCON for available	N= NON ROHS Conform	I= Individual Package		
		2= Approval for Terminal Block	B= VDE Approval Please consult EDCON for available				
	OR= Orange		C= TÜV Approval Please consult EDCON for available				
	BK= Black						

Screwless Terminal Block

Part No.: **A11L030**

DRW:	Jason	CHKD	Wilson	MATL:	Wilson	TOLERANCE	Mason	DATE	03.02.2014
APPD:	Schumi			FINISH	Jamy		Sheet No.		3 from 4

Customer:

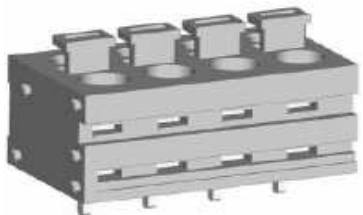

Soldering Profile Curve

Classification Reflow Profile (JEDEC J-STD-020C)

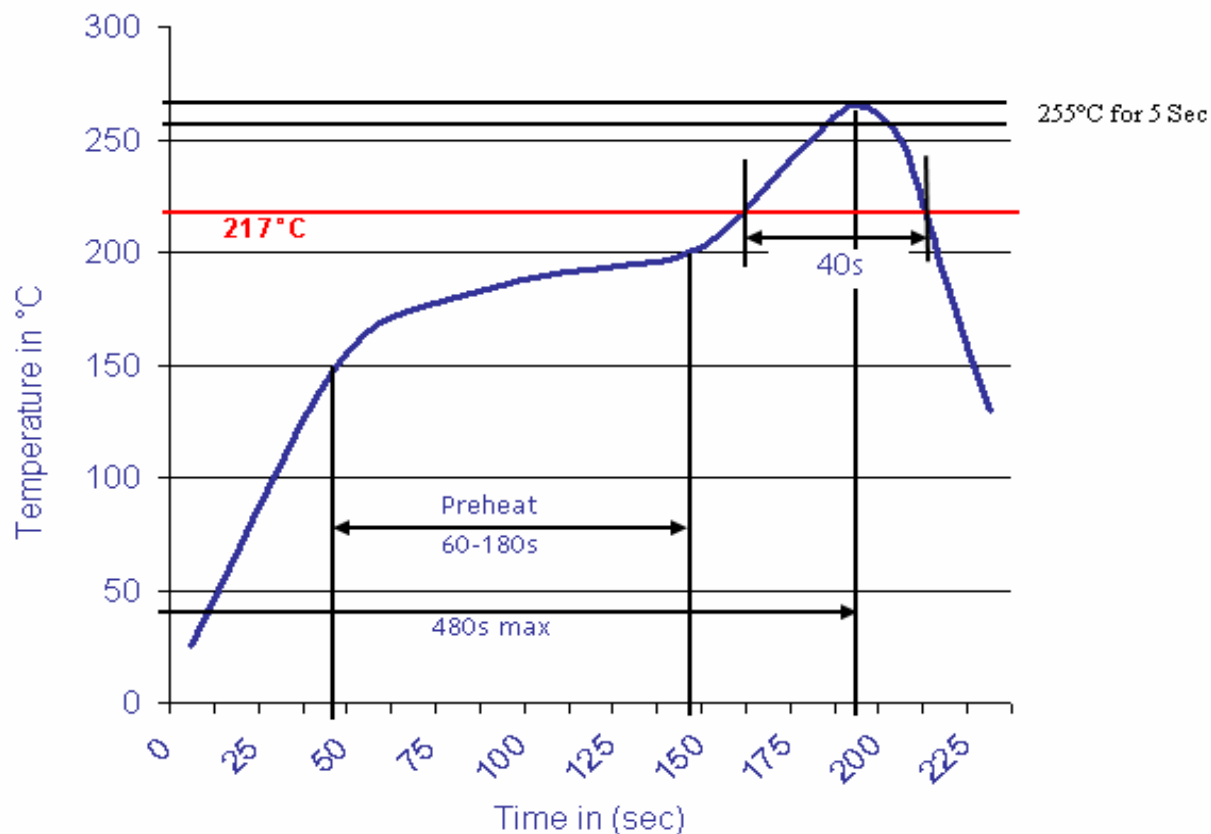

Screwless Terminal Block

Part No.: **A11L030**

Customer:

DRW:	Jason	CHKD	Wilson	MATL:	Wilson	TOLERANCE	Mason	DATE	03.02.2014
APPD:	Schumi			FINISH	Jamy		Sheet No.	4 from 4	

