

Data Sheet

Screwless Terminal Block

Pitch: 5,00 mm

Serie: A11L024

Customer Information for special Item

EDCON Customer : 0

Customer Version No. : 0

EDCON-COMPONENTS

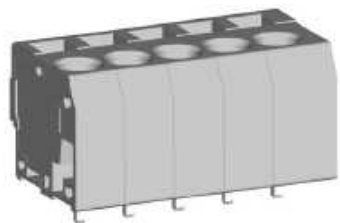

Technical Discription

Drawing (Dimension in mm)

Electrical

Standard	cULus
Rated voltage	250V
Rated current	8A
Withstanding voltage	1.5KV
Solid / Stranded wire	28-12 AWG

Mechanical

Wire strip length	6 ~ 7mm
Ambient temperature	-40°C ~ +115°C
Soldering temperature	250°C ±10°C/5 sec

Dimensions

Pitch	5.00mm
Poles	2P - 24P

Material

Housing	Thermoplastic (UL94V-0)
Pin header	Brass, Tin plated
Wire guard	Stainless steel

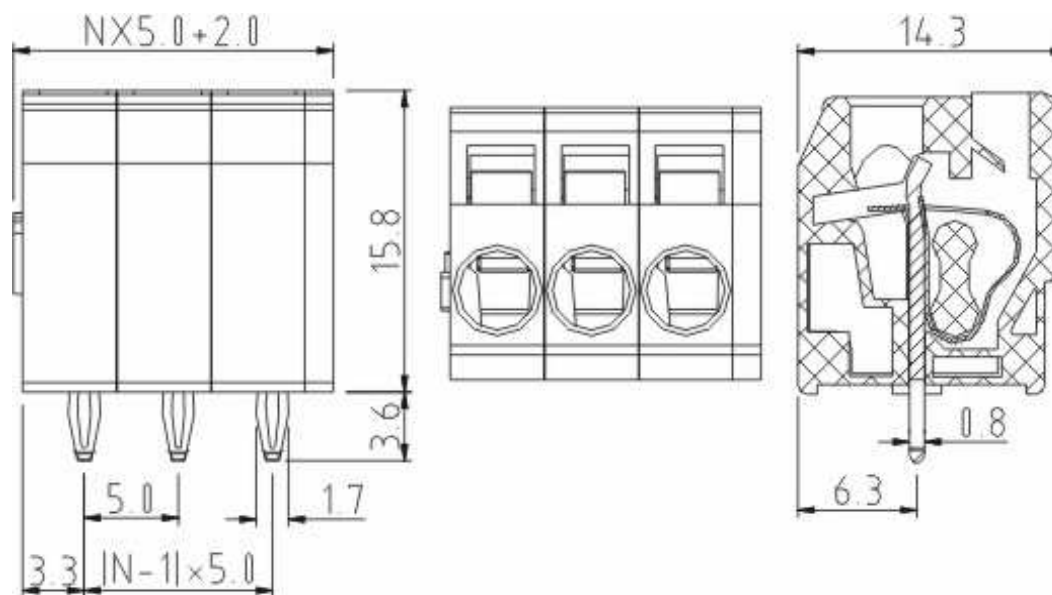

Screwless Terminal Block

Part No.: **A11L024**

Customer:

DRW:	Jason	CHKD	Wilson	MATL:	Wilson	TOLERANCE	Mason	DATE	31.01.2014
APPD:	Schumi			FINISH	Jamy		Sheet No.		1 from 4

www.edcon-components.com

email: info@edcon-components.com

EDCON-COMPONENTS

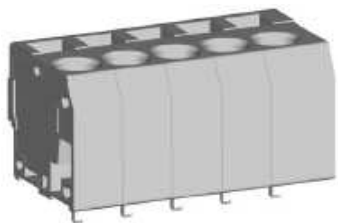

PCB Layout (Dimension in mm)

Dimensions (mm)

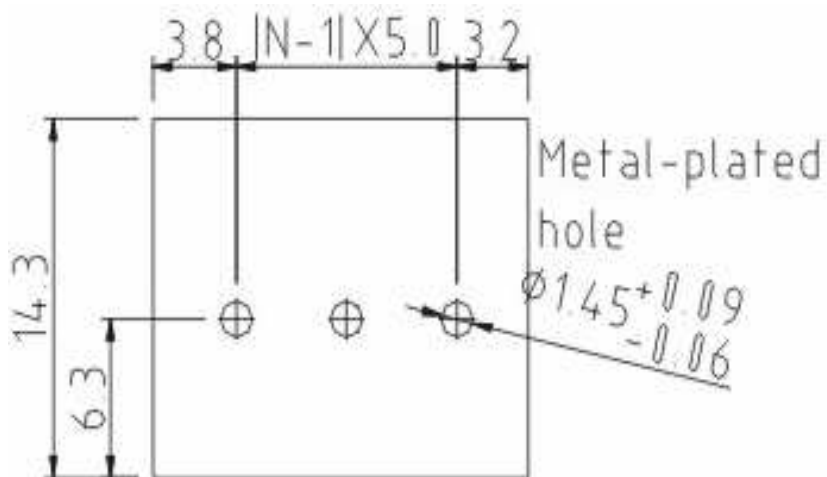

No. of Pos.	A	Tol. P	B	Tol. P
02	12,00	± 0,35	5,00	± 0,35
03	17,00	± 0,35	10,00	± 0,35
04	22,00	± 0,35	15,00	± 0,35
05	27,00	± 0,35	20,00	± 0,35
06	32,00	± 0,35	25,00	± 0,35
07	37,00	± 0,35	30,00	± 0,35
08	42,00	± 0,35	35,00	± 0,35
09	47,00	± 0,35	40,00	± 0,35
10	52,00	± 0,35	45,00	± 0,35
11	57,00	± 0,35	50,00	± 0,35
12	62,00	± 0,35	55,00	± 0,35
13	67,00	± 0,35	60,00	± 0,35
14	72,00	± 0,35	65,00	± 0,35
15	77,00	± 0,35	70,00	± 0,35
16	82,00	± 0,35	75,00	± 0,35
17	87,00	± 0,35	80,00	± 0,35
18	92,00	± 0,35	85,00	± 0,35
19	97,00	± 0,35	90,00	± 0,35
20	102,00	± 0,35	95,00	± 0,35
21	107,00	± 0,35	100,00	± 0,35
22	112,00	± 0,35	105,00	± 0,35
23	117,00	± 0,35	110,00	± 0,35
24	122,00	± 0,35	115,00	± 0,35

Screwless Terminal Block

Part No.: **A11L024**

Customer:

DRW:	Jason	CHKD	Wilson	MATL:	Wilson	TOLERANCE	Mason	DATE	31.01.2014
APPD:	Schumi			FINISH	Jamy		Sheet No.		2 from 4

EDCON-COMPONENTS

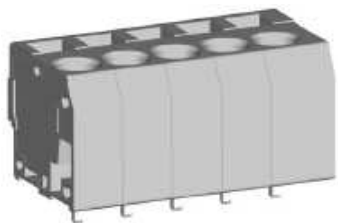

Ordering Informations

Serie	No. of Pos.	Body Color	Approval	Approval Code	ROHS	Packing	EDCON Cust. No.	Customer Version		
A11L024	02	GY	N	N	R	B				

Pitch
5,00

02= Number of Pos. Standard 2~24 Pos.	GY= Gray (Standard)	N= No Approval	N= NON Approval	R= ROHS Conform	B= Standard Package	xxxxxx= Customer Number	xxx= Customer Version ??(Printing)
	GN= Green	1= Approval for Material	A= UL /UR Approval Please consult EDCON for available	N= NON ROHS Conform	I= Individual Package		
		2= Approval for Terminal Block					
	OR= Orange		B= VDE Approval Please consult EDCON for available				
	BK= Black		C= TÜV Approval Please consult EDCON for available				

Screwless Terminal Block	
Part No.:	A11L024
Customer:	

DRW:	Jason	CHKD	Wilson	MATL:	Wilson	TOLERANCE	Mason	DATE	31.01.2014
APPD:	Schumi			FINISH	Jamy		Sheet No.		3 from 4

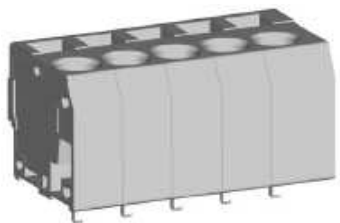

Soldering Profile Curve

Classification Reflow Profile (JEDEC J-STD-020C)

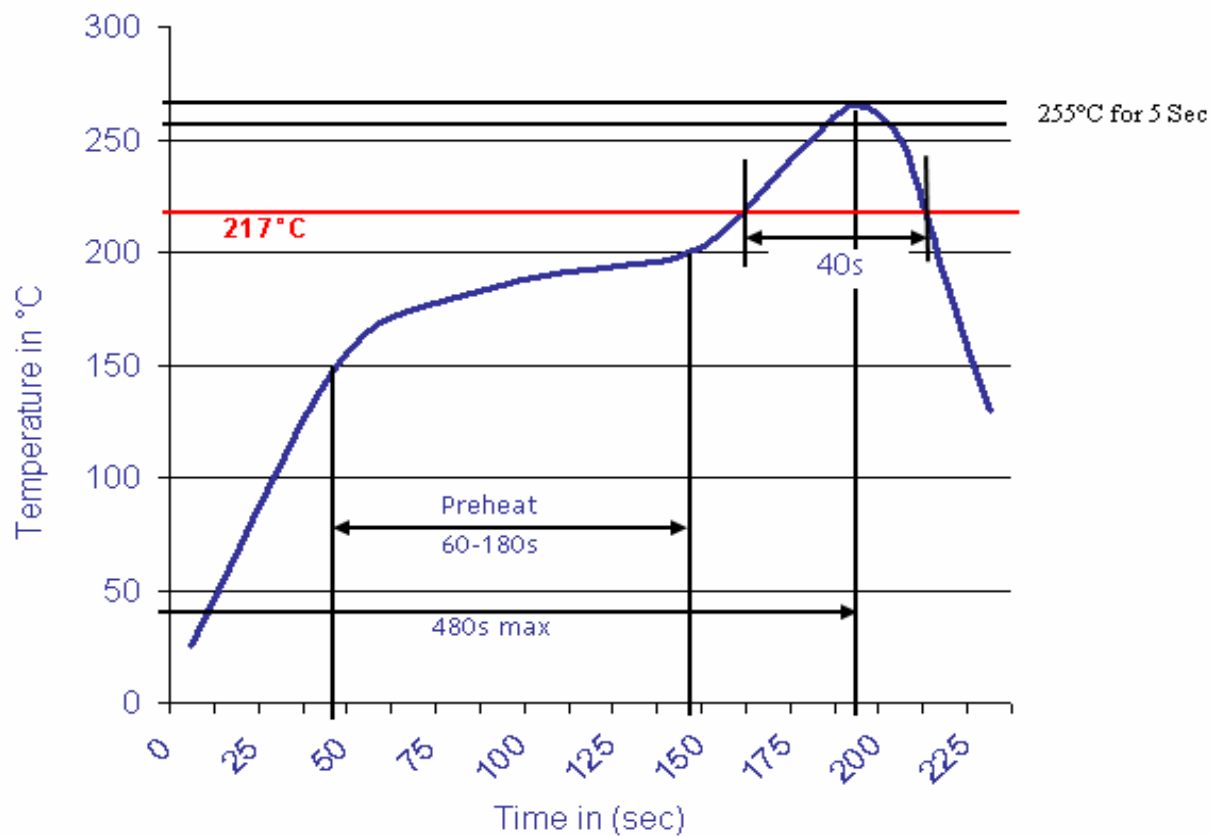

Screwless Terminal Block

Part No.: **A11L024**

Customer:

DRW:	Jason	CHKD	Wilson	MATL:	Wilson	TOLERANCE	Mason	DATE	31.01.2014
APPD:	Schumi			FINISH	Jamy		Sheet No.	4 from 4	

