

# Data Sheet

## Screwless Terminal Block

**Pitch: 5,00 mm**

**Serie: A11L023**

### Customer Information for special Item

**EDCON Customer : 0**

**Customer Version No. : 0**

# EDCON-COMPONENTS



## Technical Discription

## Drawing (Dimension in mm)

### Electrical

Standard  
 Rated voltage  
 Rated current  
 Wire range  
 Withstanding voltage

UL	IEC
300V	450V, 750V, 1000V
15A	17A
28-12 AWG	0.2-2.5mm <sup>2</sup>
AC2000V/1Min	

### Mechanical

Wire strip length  
 Operating temperature

5 ~ 6mm  
 -40°C ~ +105°C

### Dimensions

Pitch  
 Poles

5.00mm  
 1P - xxP

### Material

Housing  
 Pin header  
 Wire guard

PA66 (UL94V-0)  
 Phosphoer Bronze, Tin plated  
 Stainless steel

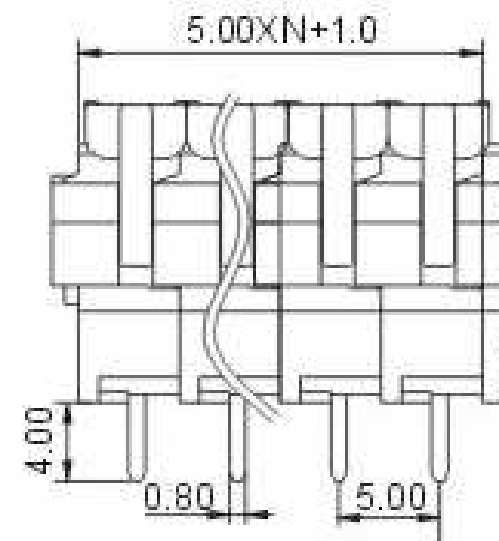
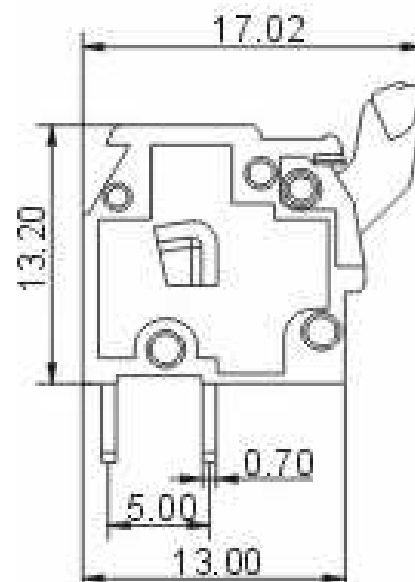

### Screwless Terminal Block

Part No.: **A11L023**

Customer:

DRW:	Jason	CHKD	Wilson	MATL:	Wilson	TOLERANCE	Mason	DATE	31.01.2014
APPD:	Schumi			FINISH	Jamy		Sheet No.		1 from 4

# EDCON-COMPONENTS



PCB Layout (Dimension in mm)

Dimensions (mm)

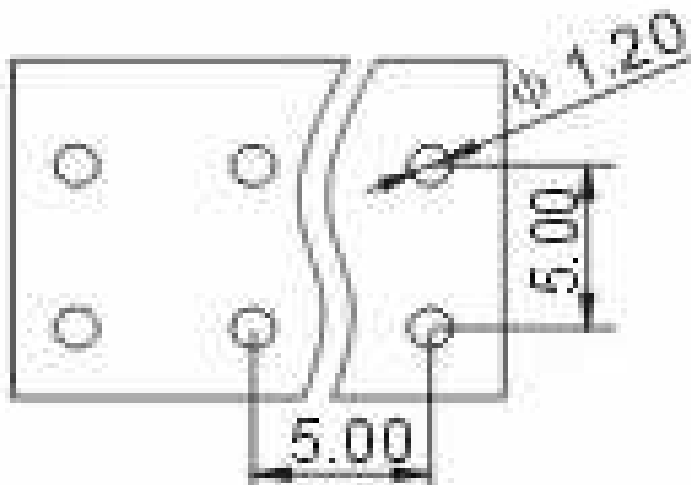

No. of Pos.	A	Tol. P	B	Tol. P
02	11,00	± 0,35	5,00	± 0,35
03	16,00	± 0,35	10,00	± 0,35
04	21,00	± 0,35	15,00	± 0,35
05	26,00	± 0,35	20,00	± 0,35
06	31,00	± 0,35	25,00	± 0,35
07	36,00	± 0,35	30,00	± 0,35
08	41,00	± 0,35	35,00	± 0,35
09	46,00	± 0,35	40,00	± 0,35
10	51,00	± 0,35	45,00	± 0,35
11	56,00	± 0,35	50,00	± 0,35
12	61,00	± 0,35	55,00	± 0,35
13	66,00	± 0,35	60,00	± 0,35
14	71,00	± 0,35	65,00	± 0,35
15	76,00	± 0,35	70,00	± 0,35
16	81,00	± 0,35	75,00	± 0,35
17	86,00	± 0,35	80,00	± 0,35
18	91,00	± 0,35	85,00	± 0,35
19	96,00	± 0,35	90,00	± 0,35
20	101,00	± 0,35	95,00	± 0,35
21	106,00	± 0,35	100,00	± 0,35
22	111,00	± 0,35	105,00	± 0,35
23	116,00	± 0,35	110,00	± 0,35
24	121,00	± 0,35	115,00	± 0,35

**Screwless Terminal Block**

Part No.: **A11L023**

DRW:	Jason	CHKD	Wilson	MATL:	Wilson	TOLERANCE	Mason	DATE	31.01.2014
APPD:	Schumi			FINISH	Jamy		Sheet No.		2 from 4

Customer:

# EDCON-COMPONENTS



## Ordering Informations

Serie	No. of Pos.	Body Color	Approval	Approval Code	ROHS	Packing	EDCON Cust. No.	Customer Version		
<b>A11L023</b>	<b>02</b>	<b>GN</b>	<b>N</b>	<b>N</b>	<b>R</b>	<b>B</b>				

Pitch:  
5,00

<b>02=</b> Number of Pos. Standard 2~24 Pos.	<b>GY=</b> Gray (Standard)	<b>N=</b> No Approval	<b>N=</b> NON Approval	<b>R=</b> ROHS Conform	<b>B=</b> Standard Package	<b>xxxxxx=</b> Customer Number	<b>xxx=</b> Customer Version ??(Printing)
	<b>GN=</b> Green	<b>1=</b> Approval for Material	<b>A=</b> UL /UR Approval Please consult EDCON for available	<b>N=</b> NON ROHS Conform	<b>I=</b> Individual Package		
		<b>2=</b> Approval for Terminal Block	<b>B=</b> VDE Approval Please consult EDCON for available				
	<b>OR=</b> Orange		<b>C=</b> TÜV Approval Please consult EDCON for available				
	<b>BK=</b> Black						

<b>Screwless Terminal Block</b>	
Part No.:	<b>A11L023</b>
Customer:	

DRW:	Jason	CHKD	Wilson	MATL:	Wilson	TOLERANCE	Mason	DATE	31.01.2014
APPD:	Schumi			FINISH	Jamy		Sheet No.		3 from 4



Soldering Profile Curve

Classification Reflow Profile (JEDEC J-STD-020C)



**Screwless Terminal Block**

Part No.: **A11L023**

DRW:	Jason	CHKD	Wilson	MATL:	Wilson	TOLERANCE	Mason	DATE	31.01.2014
APPD:	Schumi			FINISH	Jamy		Sheet No.	4 from 4	Customer:



