

Data Sheet

Screwless Terminal Block

Pitch: 5,00 mm

Serie: A11L005

Customer Information for special Item

EDCON Customer : 0

Customer Version No. : 0

EDCON-COMPONENTS



Technical Discription

Drawing (Dimension in mm)

Electrical

Rated voltage	300V
Rated current	10A
Contact resistance	20mΩ
Insulation resistance	5000MΩ / 1000V
Withstanding voltage	AC1500V/Min
Wire range	26-14 AWG / 2.5mm ²

Mechanical

Wire strip length	5 ~ 6mm
Operating temperature	-40°C ~ +105°C
Soldering temperature	+250°C/sec

Dimensions

Pitch	5.00mm
Poles	1P - xxP

Material

Housing	PA66 (UL94V-0)
Pin header	Brass, Tin plated
Wire guard	Stainless steel

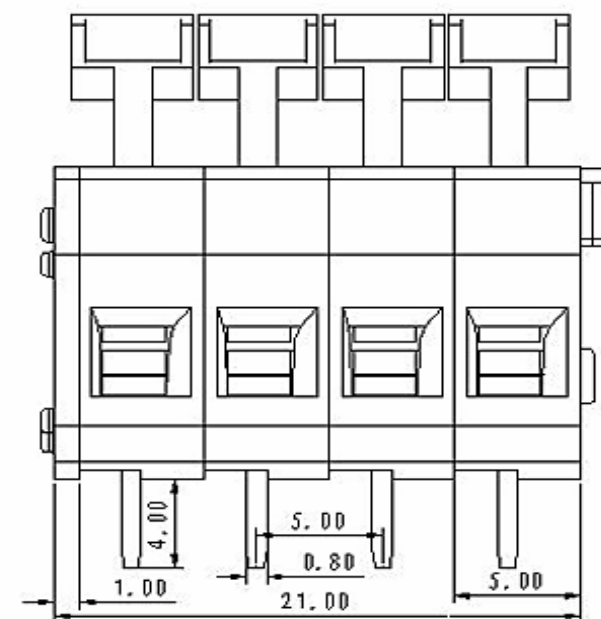
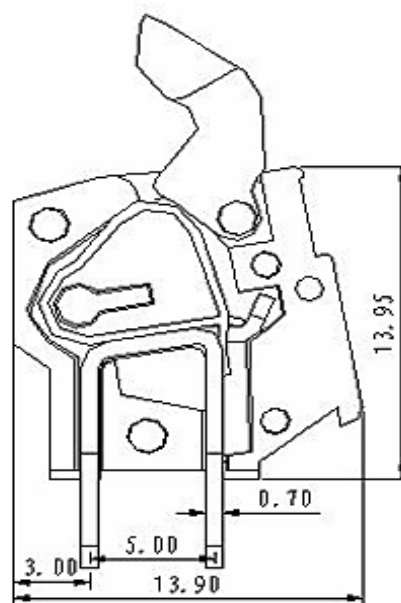

Screwless Terminal Block

Part No.: **A11L005**

Customer:

DRW:	Jason	CHKD	Wilson	MATL:	Wilson	TOLERANCE	Mason	DATE	31.01.2014
APPD:	Schumi			FINISH	Jamy		Sheet No.	1 from 4	

EDCON-COMPONENTS



PCB Layout (Dimension in mm)

Dimensions (mm)

No. of Pos.	A	Tol. P	B	Tol. P
02	11,00	± 0,35	5,00	± 0,35
03	16,00	± 0,35	10,00	± 0,35
04	21,00	± 0,35	15,00	± 0,35
05	26,00	± 0,35	20,00	± 0,35
06	31,00	± 0,35	25,00	± 0,35
07	36,00	± 0,35	30,00	± 0,35
08	41,00	± 0,35	35,00	± 0,35
09	46,00	± 0,35	40,00	± 0,35
10	51,00	± 0,35	45,00	± 0,35
11	56,00	± 0,35	50,00	± 0,35
12	61,00	± 0,35	55,00	± 0,35
13	66,00	± 0,35	60,00	± 0,35
14	71,00	± 0,35	65,00	± 0,35
15	76,00	± 0,35	70,00	± 0,35
16	81,00	± 0,35	75,00	± 0,35
17	86,00	± 0,35	80,00	± 0,35
18	91,00	± 0,35	85,00	± 0,35
19	96,00	± 0,35	90,00	± 0,35
20	101,00	± 0,35	95,00	± 0,35
21	106,00	± 0,35	100,00	± 0,35
22	111,00	± 0,35	105,00	± 0,35
23	116,00	± 0,35	110,00	± 0,35
24	121,00	± 0,35	115,00	± 0,35

Screwless Terminal Block

Part No.: **A11L005**

DRW:	Jason	CHKD	Wilson	MATL:	Wilson	TOLERANCE	Mason	DATE	31.01.2014	Customer:
APPD:	Schumi			FINISH	Jamy		Sheet No.	2 from 4		

EDCON-COMPONENTS



Ordering Informations

Serie	No. of Pos.	Body Color	Approval	Approval Code	ROHS	Packing	EDCON Cust. No.	Customer Version		
A11L005	02	GN	N	N	R	B				

Pitch:
5,00

02= Number of Pos. Standard 2~24 Pos.	GY= Gray (Standard)	N= No Approval	N= NON Approval	R= ROHS Conform	B= Standard Package	xxxxxx= Customer Number	xxx= Customer Version ??(Printing)
	GN= Green	1= Approval for Material	A= UL /UR Approval Please consult EDCON for available	N= NON ROHS Conform	I= Individual Package		
		2= Approval for Terminal Block					
	OR= Orange		B= VDE Approval Please consult EDCON for available				
	BK= Black		C= TÜV Approval Please consult EDCON for available				

Screwless Terminal Block	
Part No.:	A11L005
Customer:	

DRW:	Jason	CHKD	Wilson	MATL:	Wilson	TOLERANCE	Mason	DATE	31.01.2014
APPD:	Schumi			FINISH	Jamy		Sheet No.		3 from 4



Soldering Profile Curve

Classification Reflow Profile (JEDEC J-STD-020C)

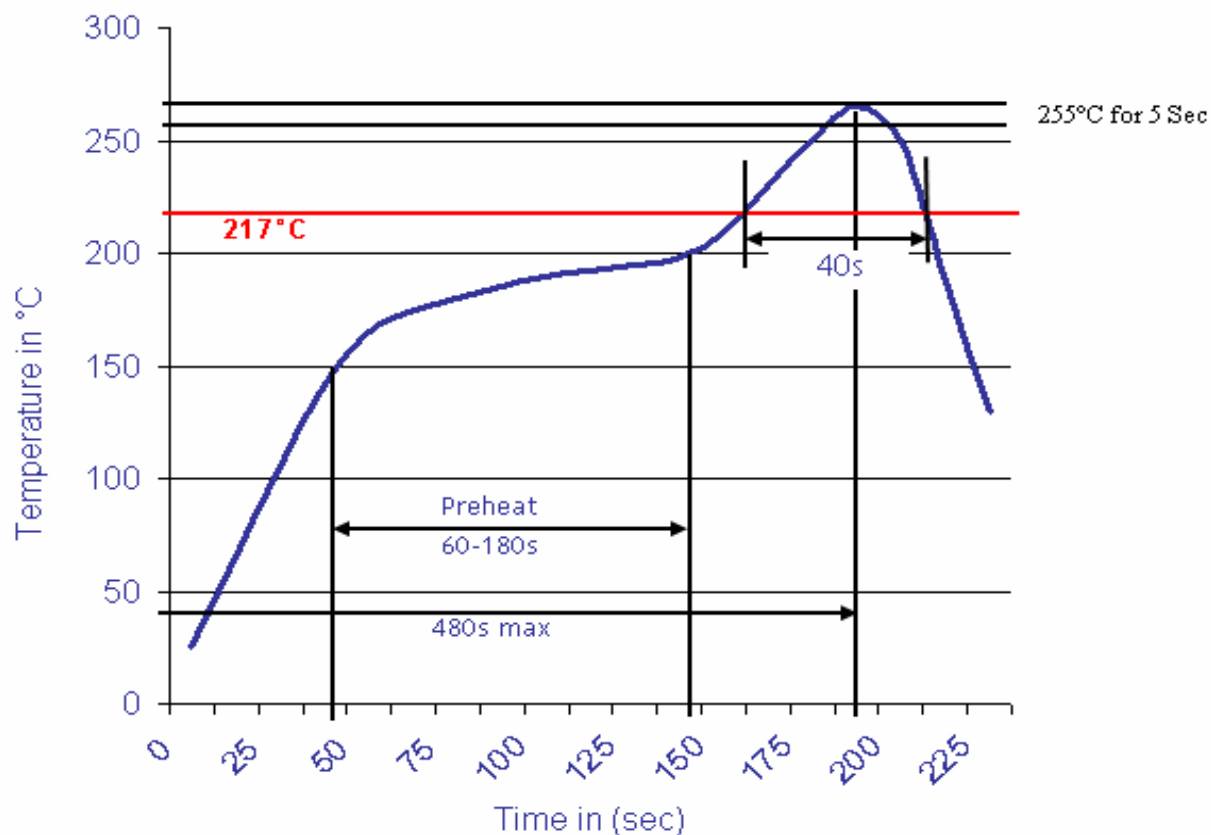

Screwless Terminal Block

Part No.: **A11L005**

Customer:

DRW:	Jason	CHKD	Wilson	MATL:	Wilson	TOLERANCE	Mason	DATE	31.01.2014
APPD:	Schumi			FINISH	Jamy		Sheet No.	4 from 4	

