

Data Sheet

Screwless Terminal Block

Pitch: 4,57 mm

Serie: A11K001

Customer Information for special Item

EDCON Customer : 0

Customer Version No. : 0

EDCON-COMPONENTS

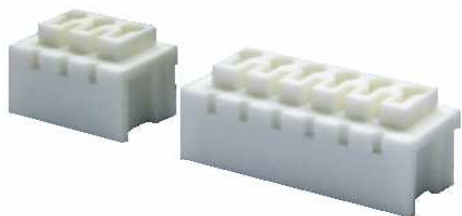

Technical Discription

Drawing (Dimension in mm)

Electrical

Standard
 Rated voltage
 Rated current
 Withstanding voltage
 Wire range
 Soldid / Stranded wire

| | |
|---------------------------|------|
| cULus | VDE |
| 300V | 250V |
| 2A | 2A |
| 1.6KV | 2KV |
| 0.5 ~ 0.75mm ² | |
| 18 AWG | |

Mechanical

Wire strip length
 Ambient temperature
 Soldering temperature

6 ~ 7mm
 -30°C ~ +105°C
 250°C ±10°C/5 sec

Dimensions

Pitch
 Poles

4.57mm
 3P, 6P

Material

Housing
 Pin header
 Wire guard

Thermoplastic (UL94V-0)
 PhBz, Tin plated
 Stainless steel

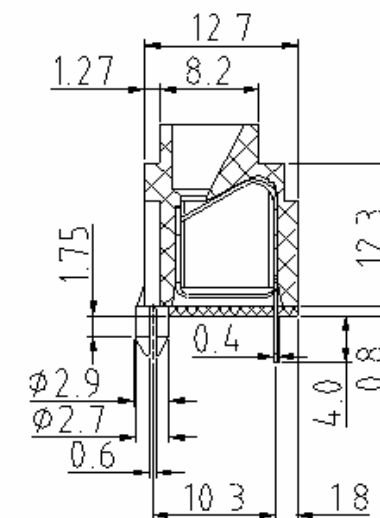
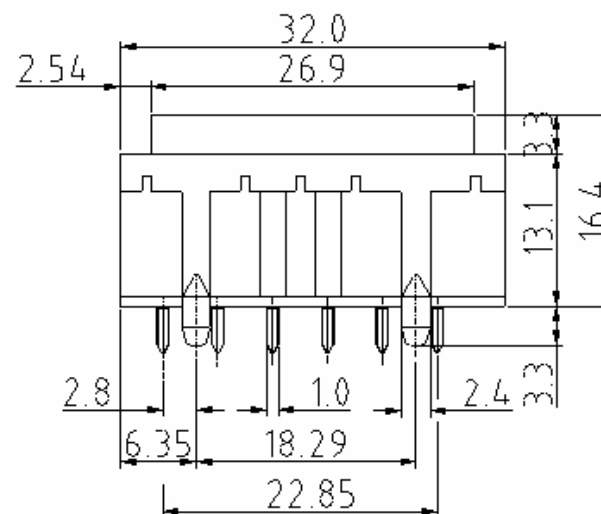

Screwless Terminal Block

Part No.: **A11K001**

Customer:

| | | | | | | | | | |
|-------|--------|------|--------|--------|--------|-----------|-----------|----------|------------|
| DRW: | Jason | CHKD | Wilson | MATL: | Wilson | TOLERANCE | Mason | DATE | 31.01.2014 |
| APPD: | Schumi | | | FINISH | Jamy | | Sheet No. | 1 from 4 | |

EDCON-COMPONENTS

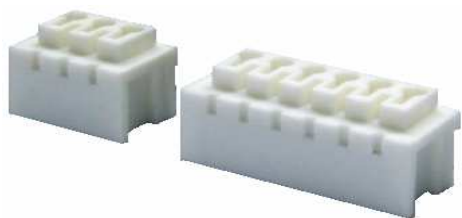

PCB Layout (Dimension in mm)

Dimensions (mm)

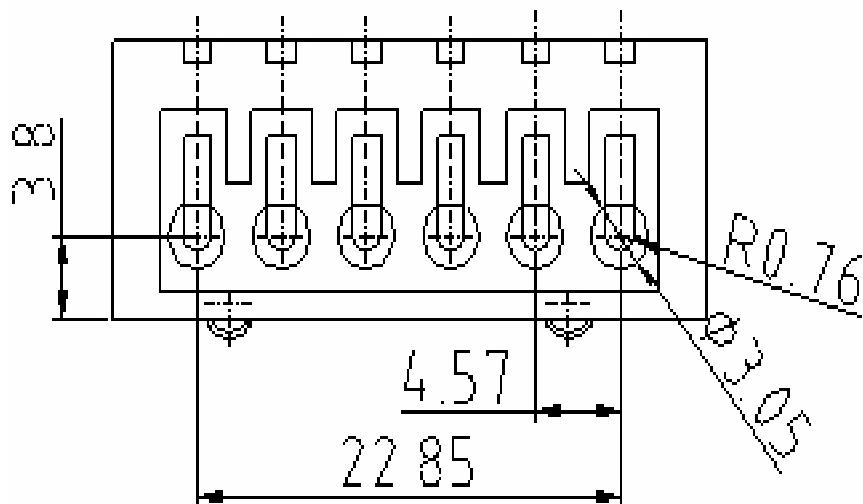

| No. of Pos. | A | Tol. P | B | Tol. P |
|-------------|-------|------------|-------|------------|
| 03 | 18,29 | $\pm 0,35$ | 9,14 | $\pm 0,35$ |
| 06 | 32,00 | $\pm 0,35$ | 22,85 | $\pm 0,35$ |

| No. of Pos. | A | Tol. P | B | Tol. P |
|-------------|---|--------|---|--------|
| | | | | |
| | | | | |
| | | | | |
| | | | | |
| | | | | |
| | | | | |
| | | | | |
| | | | | |
| | | | | |
| | | | | |
| | | | | |
| | | | | |
| | | | | |
| | | | | |
| | | | | |
| | | | | |
| | | | | |
| | | | | |
| | | | | |
| | | | | |
| | | | | |
| | | | | |
| | | | | |
| | | | | |
| | | | | |

Screwless Terminal Block

Part No.: **A11K001**

| | | | | |
|--------------|--------------|--------------|------------------|------------------|
| DRW: Jason | CHKD: Wilson | MATL: Wilson | TOLERANCE: Mason | DATE: 31.01.2014 |
| APPD: Schumi | FINISH: Jamy | Sheet No.: | 2 from 4 | Customer: |

EDCON-COMPONENTS

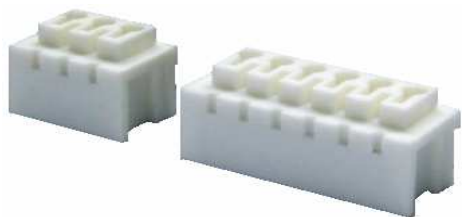

Ordering Informations

| Serie | No. of Pos. | Body Color | Approval | Approval Code | ROHS | Packing | EDCON Cust. No. | Customer Version | | |
|-------|-------------|------------|----------|---------------|------|---------|-----------------|------------------|--|--|
|-------|-------------|------------|----------|---------------|------|---------|-----------------|------------------|--|--|

| | | | | | | | | | | |
|----------------|-----------|-----------|----------|----------|----------|----------|--|--|--|--|
| A11K001 | 03 | GY | N | N | R | B | | | | |
|----------------|-----------|-----------|----------|----------|----------|----------|--|--|--|--|

| | | | | | | | | | | |
|---------------|---|---|--|--|--|--|---------------------------------|--|--|--|
| Pitch 4,57 | 03 = Number of Pos. Standard 3,6 Pos. | GY = Gray (Standard) GN = Green OR = Orange BK = Black | N = No Approval 1 = Approval for Material 2 = Approval for Terminal Block | N = NON Approval A = UL /UR Approval Please consult EDCON for available B = VDE Approval Please consult EDCON for available C = TÜV Approval Please consult EDCON for available | R = ROHS Conform N = NON ROHS Conform | B = Standard Package I = Individual Package | xxxxxx = Customer Number | xxx = Customer Version ??(Printing) | | |
|---------------|---|---|--|--|--|--|---------------------------------|--|--|--|

Screwless Terminal Block

Part No.: **A11K001**

| | | | | | | | | | |
|-------|--------|------|--------|--------|--------|-----------|-----------|------|------------|
| DRW: | Jason | CHKD | Wilson | MATL: | Wilson | TOLERANCE | Mason | DATE | 31.01.2014 |
| APPD: | Schumi | | | FINISH | Jamy | | Sheet No. | | 3 from 4 |

Customer:

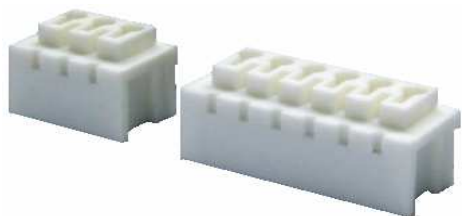

Soldering Profile Curve

Classification Reflow Profile (JEDEC J-STD-020C)

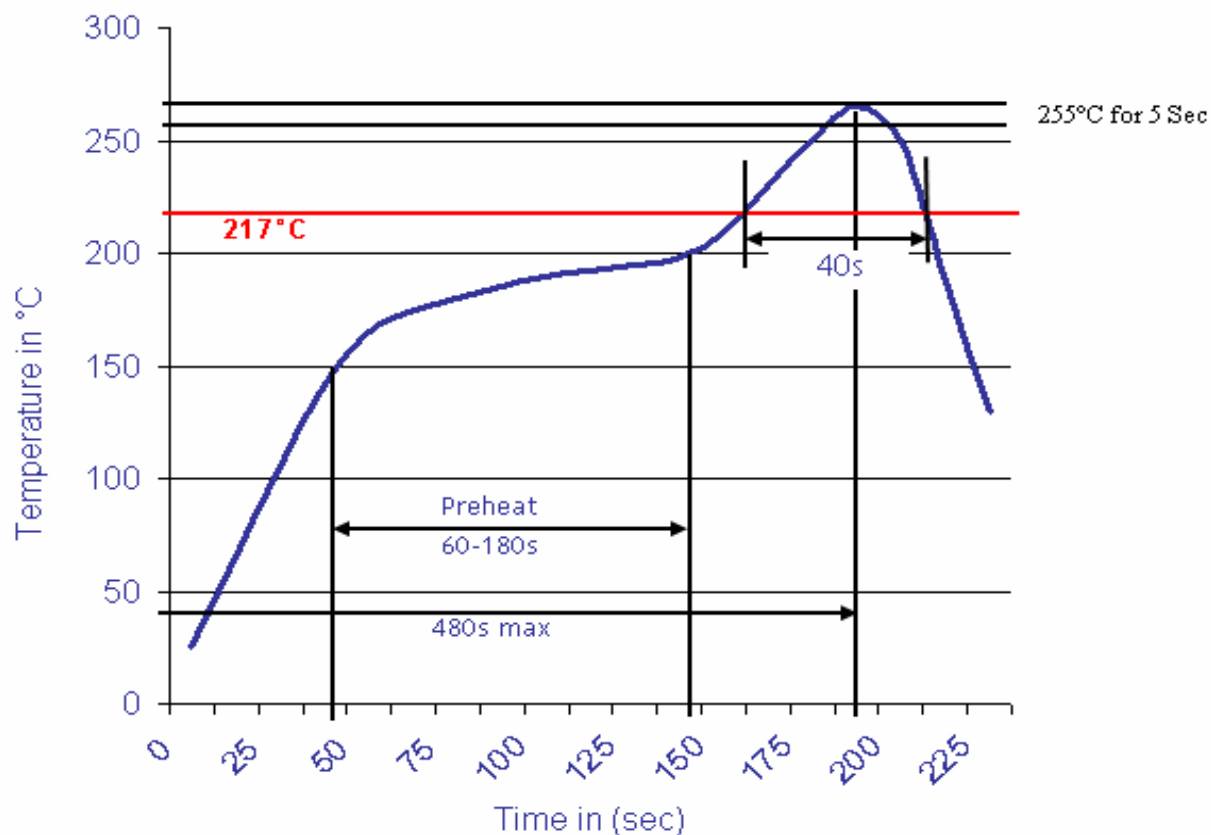

Screwless Terminal Block

Part No.: **A11K001**

Customer:

| | | | | | | | | | |
|-------|--------|------|--------|--------|--------|-----------|-----------|----------|------------|
| DRW: | Jason | CHKD | Wilson | MATL: | Wilson | TOLERANCE | Mason | DATE | 31.01.2014 |
| APPD: | Schumi | | | FINISH | Jamy | | Sheet No. | 4 from 4 | |

